

SERIES: VLED15 | DESCRIPTION: LED DRIVER
FEATURES

- constant current
- high efficiency
- 90~135 Vac and 176~265 Vac input range available
- 0.35~1.5 A output current
- operates with industry standard dimmers
- compact encapsulated assembly
- active power factor correction
- over voltage, over current, over temperature protection max., short circuit protection: auto recovery
- high temperature operation (up to 90°C case)
- UL approved, ENEC approved, CE Mark
- long life > 50,000 hours



MODEL	output voltage ¹		output current		output wattage	efficiency
	min (Vdc)	max (Vdc)	min (mA)	max (mA)	max (W)	max (%)
VLED15-120-350	24	48	0	350	16.8	80
VLED15-120-480	10	13.5	0	480	6.5	80
VLED15-120-600	8	12	0	600	7.2	80
VLED15-120-700	16	24	0	700	16.8	80
VLED15-120-800	8	12	0	800	9.6	80
VLED15-120-900	10	16	0	900	14.4	80
VLED15-120-900L	8	12	0	900	10.8	80
VLED15-120-1000	10	16	0	1,000	16	80
VLED15-120-1200	10	14.1	0	1,200	16.92	80
VLED15-120-1250	8	12	0	1,250	15	80
VLED15-120-1400 ²	8	11.5	0	1,400	16.1	80
VLED15-120-1500	5	10	0	1,500	15	80
VLED15-230-350	24	48	0	350	16.8	80
VLED15-230-480	10	13.5	0	480	6.5	80
VLED15-230-600	8	12	0	600	7.2	80
VLED15-230-700	16	24	0	700	16.8	80
VLED15-230-800	8	12	0	800	9.6	80
VLED15-230-900	10	16	0	900	14.4	80
VLED15-230-900L	8	12	0	900	10.8	80
VLED15-230-1000	10	16	0	1,000	16	80
VLED15-230-1200	10	14.1	0	1,200	16.92	80
VLED15-230-1250	8	12	0	1,250	15	80
VLED15-230-1400 ²	8	11.5	0	1,400	16.1	80
VLED15-230-1500	5	10	0	1,500	15	80

- Note:
1. Total LED forward voltage must be within these ratings under all conditions including dimming
 2. 80°C maximum case rating
 3. Ripple Current: <40% (p-p) of maximum Output Current with no dimming

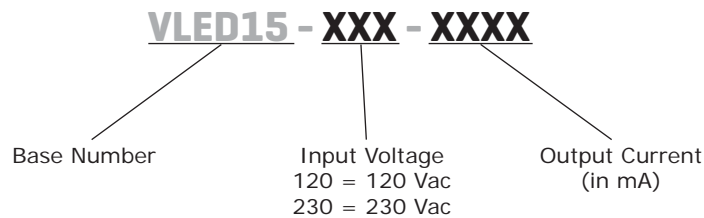
PART NUMBER KEY**INPUT**

parameter	conditions/description	min	typ	max	units
voltage		90		135	Vac
		176		265	Vac
frequency		47		63	Hz
input current	at 115 Vac			0.22	A
inrush current	at 25°C			5	A
power factor	at 120 Vac	90			%

OUTPUT

parameter	conditions/description	min	typ	max	units
voltage accuracy	of set point		±5		%
load regulation			±5		%

PROTECTION

parameter	conditions/description	min	typ	max	units
over voltage protection	auto restart				
over current protection	auto restart				
short circuit protection	auto restart				
control	output dims without any flicker				
dimming range (conduction angle/output)	use with incandescent dimmer	30		147	degrees
over temperature protection	auto restart				

SAFETY & COMPLIANCE

parameter	conditions/description	min	typ	max	units
isolation	meets the UL 60950-1 reinforced, double insulation NEC (Class 2) EN 60598-1 class II				
safety approvals	UL 60950-1, LPS, UL 8750, EN61347-2-13				
EMI/EMC	EN 55015 class B, FCC class 47 CFR part 15 class B, EN 61000-4-(2,3,4,5,6,11), IEC 61000-3-(2,3) ANSI c62.41-1991 category A1, 2.5 kV Ringwave				
harmonics	meets EN 61000-3-(2,3)				
leakage current	at 120 Vac			0.25	mA
RoHS compliant	yes				

ENVIRONMENTAL

parameter	conditions/description	min	typ	max	units
operating temperature		-30		90	°C
storage temperature		-40		95	°C
operating humidity	non-condensing	5		95	%
surface temperature	exposed surfaces, under all operating conditions			90	°C

MECHANICAL

parameter	conditions/description	min	typ	max	units
dimensions	82 x 56 x 29 (3.21 x 2.21 x 1.13 inch)				mm
weight			145 5.1		g oz

MECHANICAL DRAWING

units: mm
 tolerance: ± 0.3 mm
 unless otherwise specified

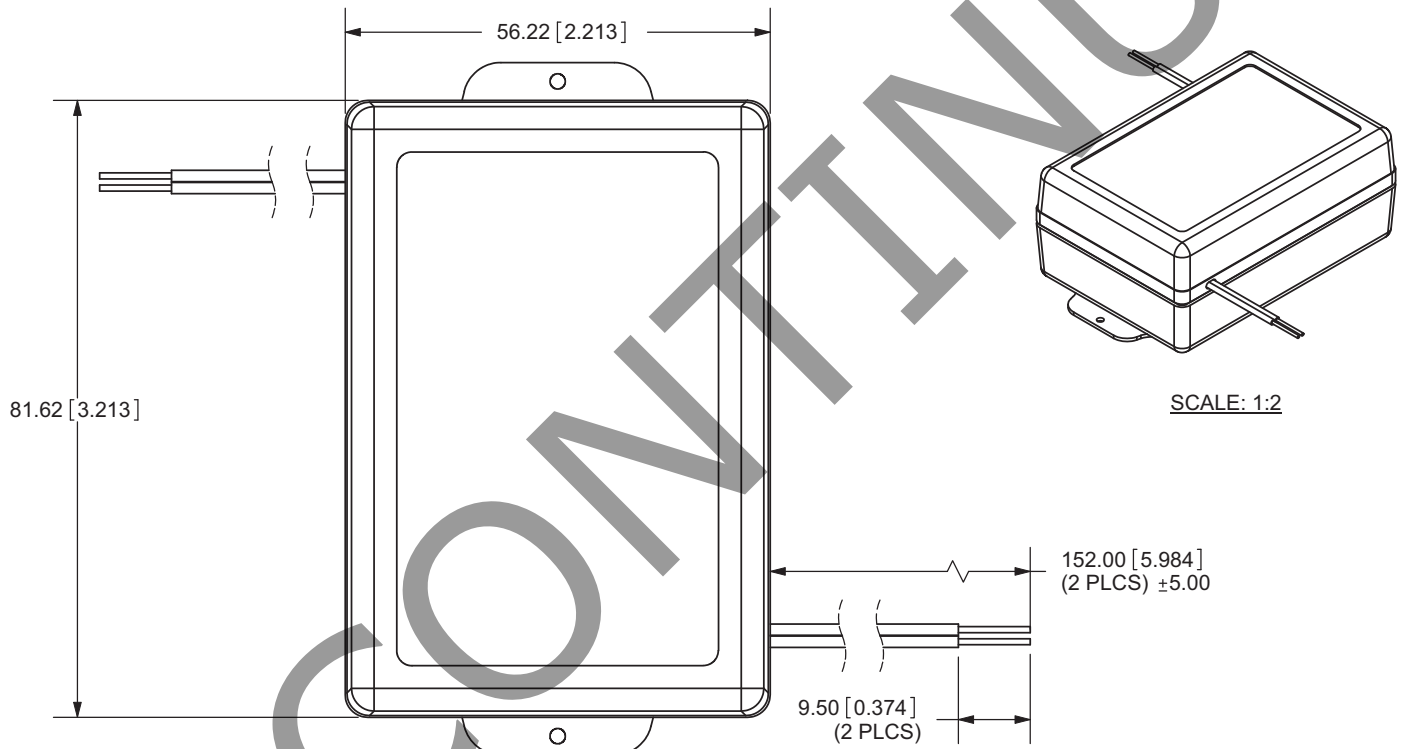

DIMMING REQUIREMENTS

Dimming of the driver shall be possible with standard triac based incandescent dimmers that chops the AC voltage as shown below or with Electronic Low Voltage dimmers that employ reverse phase control.

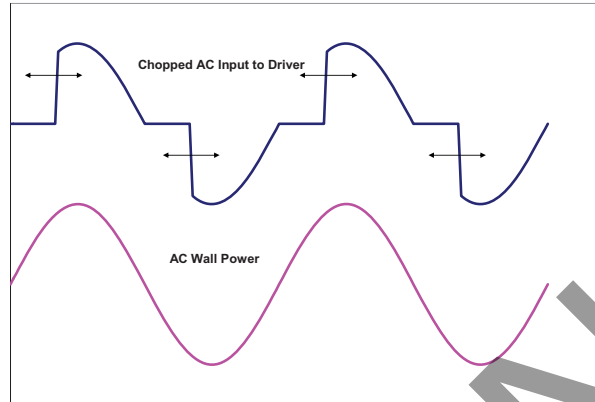

During the rapid rise time of the AC voltage when the dimmer turns on, the driver shall not generate any voltage or current oscillations and inrush current shall be controlled. During the on time of the AC input, the driver shall regulate the output. The RMS value of the driver output current shall be proportional to the on time of the AC input voltage. Care must be taken to assure that the minimum load requirements are met. Multiple drivers/LEDs may be connected to the dimmer in order to meet the minimum load requirement.

DIMMING RANGE

When operating with an incandescent dimmer, the RMS output current shall vary depending upon the conduction angle and RMS value of the applied AC input voltage. The following graph shows the typical output versus conduction angle at various line voltages.

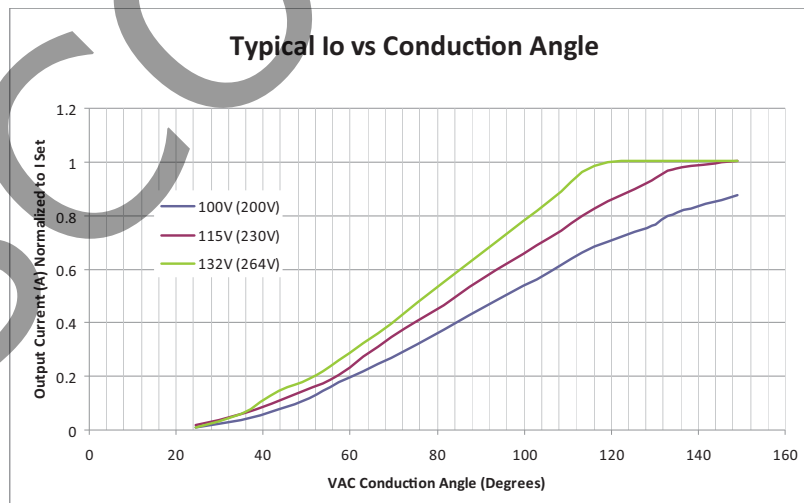

The specified dimming range shall be from 30 degrees through 147 degrees conduction angle. Operation throughout this dimming range shall be monotonic and produce a smooth transition of light output in both directions of the dimming range. At 120 Vac or 240 Vac input, the driver shall achieve full rated output current at less than 147 degree conduction angle.

REVISION HISTORY

rev.	description	date
1.0	initial release	07/29/2010
1.01	model update and added dimensions	03/21/2011
1.02	applied new spec template	02/15/2012
1.03	updated input voltage	04/24/2012
1.04	new template applied	07/18/2012
1.05	corrected output current units	09/16/2013

The revision history provided is for informational purposes only and is believed to be accurate.



Headquarters
20050 SW 112th Ave.
Tualatin, OR 97062
800.275.4899

Fax 503.612.2383
cui.com
techsupport@cui.com

CUI offers a one (1) year limited warranty. Complete warranty information is listed on our website.

CUI reserves the right to make changes to the product at any time without notice. Information provided by CUI is believed to be accurate and reliable. However, no responsibility is assumed by CUI for its use, nor for any infringements of patents or other rights of third parties which may result from its use.

CUI products are not authorized or warranted for use as critical components in equipment that requires an extremely high level of reliability. A critical component is any component of a life support device or system whose failure to perform can be reasonably expected to cause the failure of the life support device or system, or to affect its safety or effectiveness.