

SERIES: AMT20 | **DESCRIPTION:** MODULAR ABSOLUTE ENCODER

FEATURES

- patented capacitive ASIC technology
- low power consumption
- SPI configurable settings
- digitally set zero position alignment
- 12-bit absolute position via SPI (4096 positions)
- incremental resolutions up to 1024 PPR
- index pulse
- compact modular package with locking hub for ease of installation
- 7 different mounting hole options
- -40~125°C operating temperature

ELECTRICAL

| parameter | conditions/description | min | typ | max | units |
|---------------------|------------------------------|---------|-----|-----|-------|
| power supply | VDD | 4.5 | 5 | 5.5 | V |
| current consumption | with unloaded output | | 8 | 10 | mA |
| output high level | | VDD-0.8 | | | V |
| output low level | | | | 0.4 | V |
| output current | CMOS sink/source per channel | | | 2 | mA |
| rise/fall time | | | 30 | | ns |

INCREMENTAL CHARACTERISTICS

| parameter | conditions/description | min | typ | max | units |
|-------------------------------------|---|-----|-----|-----|---------|
| channels | quadrature A, B, and Z index | | | | |
| waveform | CMOS voltage square wave | | | | |
| phase difference | A leads B for CCW rotation (viewed from front) | | 90 | | degrees |
| quadrature resolutions ¹ | 96, 192, 200, 250, 384, 400, 500, 512, 768, 800, 1000, 1024 | | | | PPR |
| index | one pulse per 360 degree rotation | | | | |
| accuracy | | | 0.2 | | degrees |
| quadrature duty cycle | | | 50 | | % |

Notes: 1. Resolution selected via AMT Demo Board. Default resolution set to 1024 PPR.

ABSOLUTE POSITION CHARACTERISTICS

| parameter | conditions/description | min | typ | max | units |
|------------|---|-----|-----|-----|---------|
| resolution | | | | 12 | bits |
| positions | encoder can be zero-set via SPI or AMT Demo Board | | | | |
| accuracy | | | 0.2 | | degrees |

MECHANICAL

| parameter | conditions/description | min | typ | max | units |
|--------------------|------------------------|-----|------|------|-------|
| motor shaft length | | 9 | | | mm |
| weight | | | 15.7 | | g |
| axial play | | | | ±0.3 | mm |
| rotational speed | | | | 8000 | RPM |

ENVIRONMENTAL

| parameter | conditions/description | min | typ | max | units |
|-----------------------|--|-----|-----|-----|-------|
| operating temperature | | -40 | | 125 | °C |
| humidity | non-condensing | | | 85 | % |
| vibration | 10~500 Hz, 5 minute sweep, 2 hours on each XYZ | | | 5 | G |
| shock | 3 pulses, 6 ms, 3 on each XYZ | | | 200 | G |
| RoHS | 2011/65/EU | | | | |

SERIAL INTERFACE

| parameter | conditions/description | min | typ | max | units |
|------------------------|--|-----|-----|-----|-------|
| protocol | Serial Peripheral Interface (SPI) | | | | |
| controller | SPI driven by onboard Microchip PIC16F690 ¹ | | | | |
| data rate ¹ | | | 1 | | MHz |

Note: 1. See Microchip documentation for additional details.

WAVEFORMS

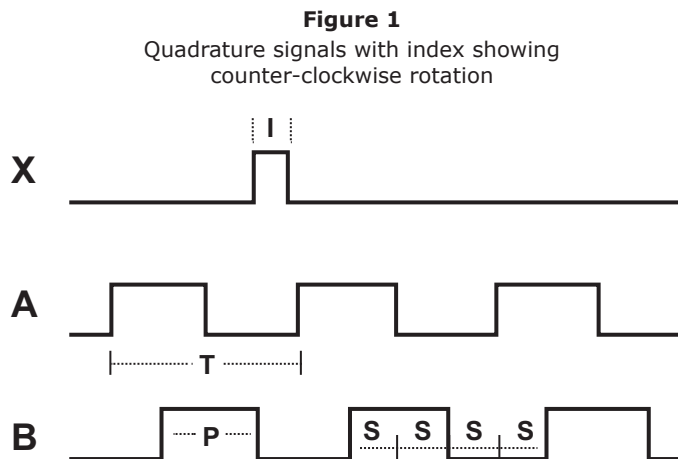

The following parameters are defined by the resolution selected for each encoder, where R = resolution.

| Parameter | Description | Expression | Units |
|-----------|-----------------|------------|--------------------|
| T | period | 360/R | mechanical degrees |
| P | pulse width | T/2 | mechanical degrees |
| I | index width | P/2 | mechanical degrees |
| S | A/B state width | P/2 | mechanical degrees |

PART NUMBER KEY

The AMT203 is designed for 12 bit binary (4,096) operation. For customers who may use the optional quadrature output, one of the resolutions below may be selected as the default quadrature output.

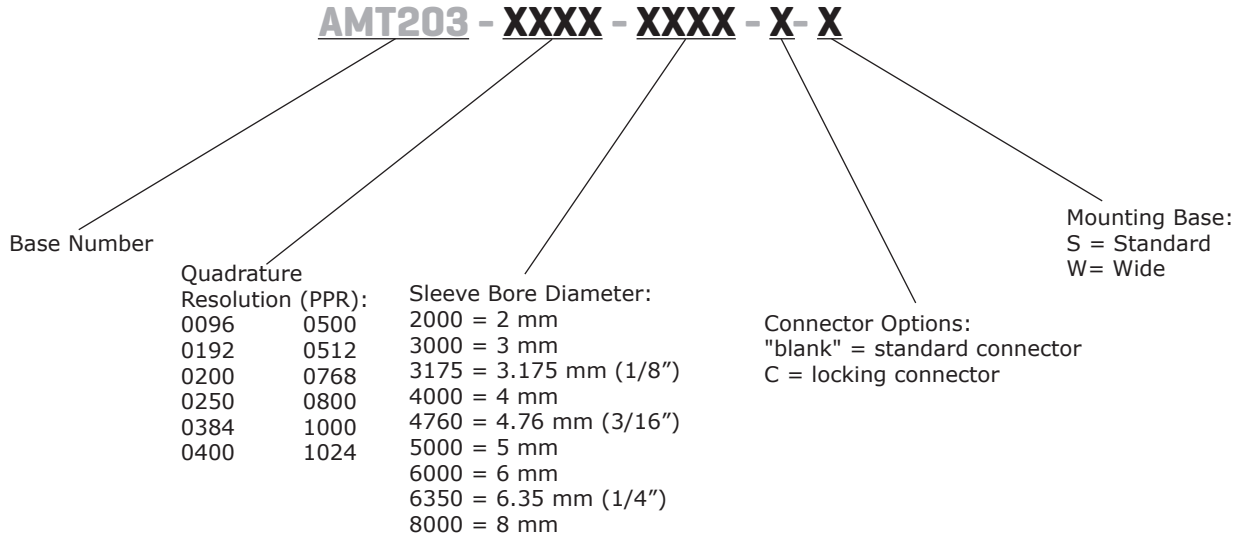

Note: 1. Conformal coating available upon request

AMT203-V KIT

In order to provide maximum flexibility for our customers, the AMT203 series is provided in kit form standard. This allows the user to implement the encoder into a range of applications using one sku#, reducing engineering and inventory costs.

| SLEEVES | | | | | | | | |
|----------------|--------|--------------------|------|--------------------|-------|-----|-------------------|------|
| | | | | | | | | |
| 2mm | 3mm | 1/8 inch (3.175mm) | 4mm | 3/16 inch (4.76mm) | 5mm | 6mm | 1/4 inch (6.35mm) | 8mm |
| Light Sky Blue | Orange | Purple | Gray | Yellow | Green | Red | Snow | Blue |

| | | | | |
|-------------|------------------|----------------------|---------------|---------------|
| BASE | TOP COVER | SHAFT ADAPTER | TOOL A | TOOL C |
| | | | | |

ENCODER INTERFACE

| PINOUT CONNECTOR | |
|------------------|--------|
| Function | |
| # | AMT203 |
| 1 | N/A |
| 2 | CSB |
| 3 | MISO |
| 4 | GND |
| 5 | SCK |
| 6 | +5 V |
| 7 | MOSI |
| 8 | B |
| 9 | N/A |
| 10 | A |
| 11 | N/A |
| 12 | Z |
| 13 | N/A |
| 14 | N/A |

STANDARD CONNECTOR OPTION

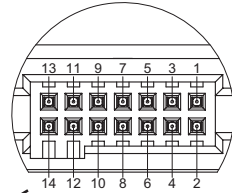
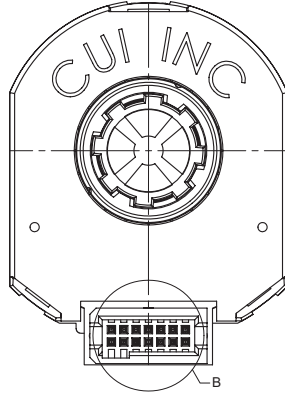

DETAIL B
SCALE 4 : 1

Mating Connector:
Samtec ISDF-07-D

LOCKING CONNECTOR OPTION

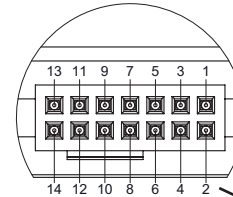
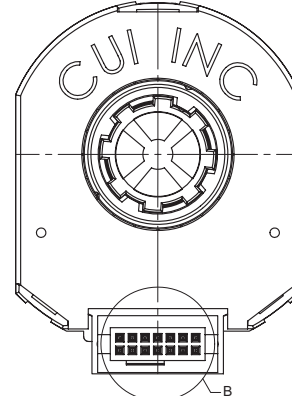

DETAIL B
SCALE 4 : 1

Mating Connector:
Samtec ISDF-07-D-L

Encoder Side

Demo Board Side

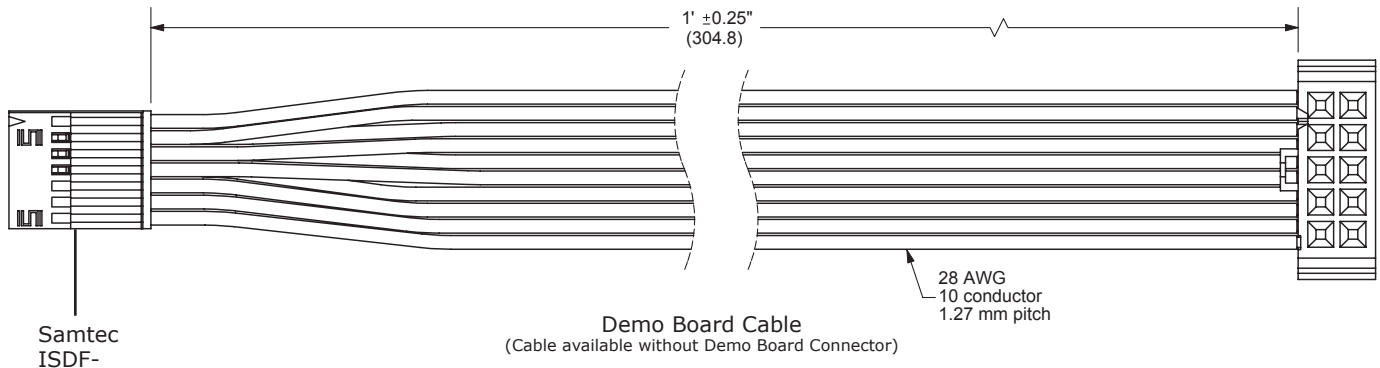

MECHANICAL DRAWING

AMT203

units: mm

tolerance: ± 0.1

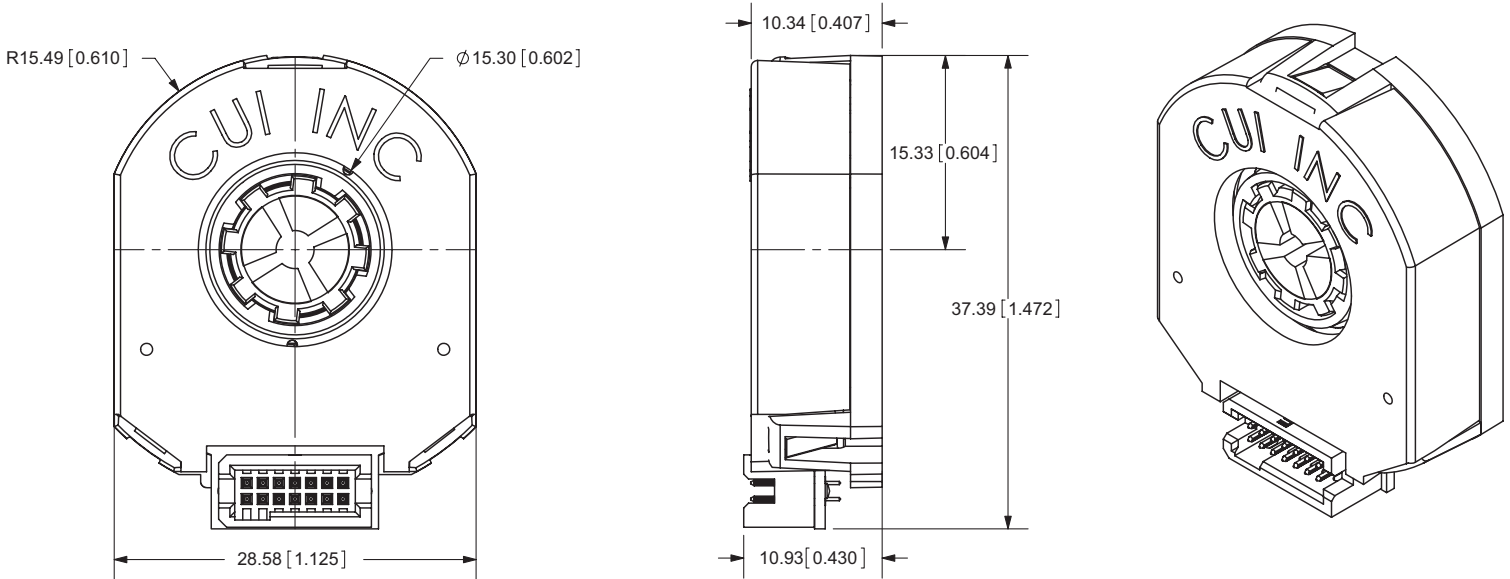

AMT203 WIDE BASE

units: mm

tolerance: ± 0.1

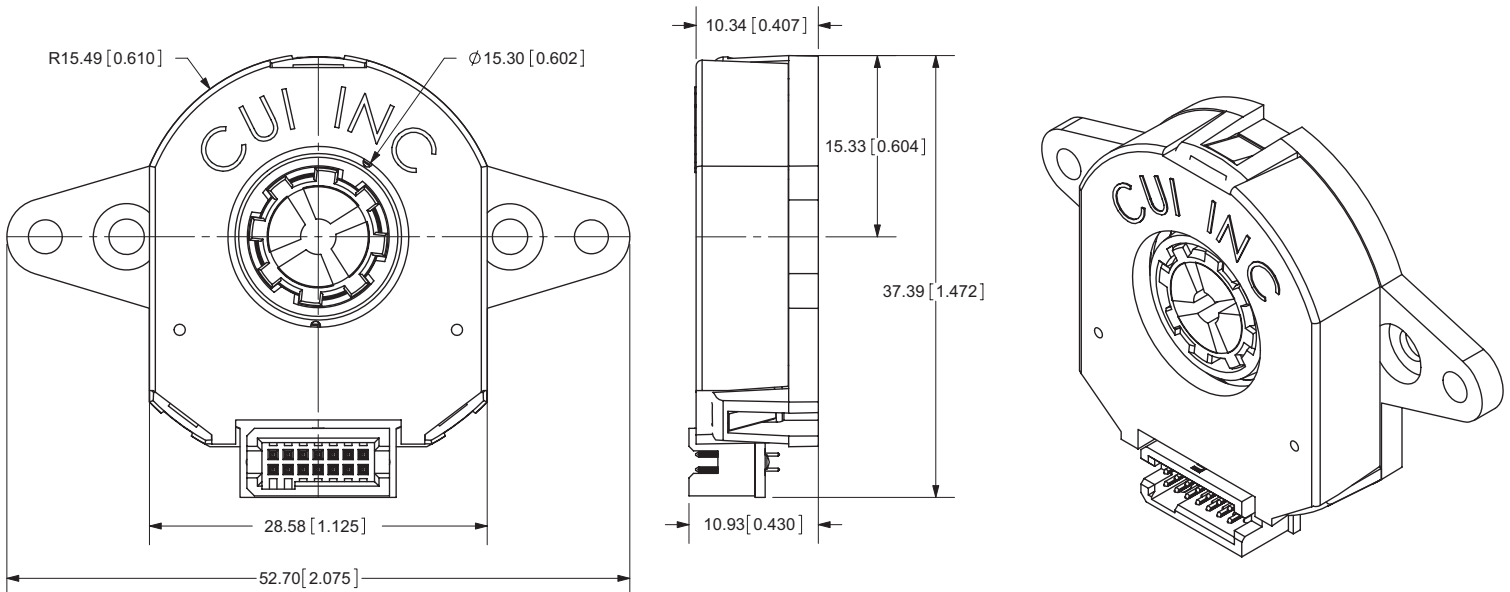

MECHANICAL DRAWING (CONTINUED)

MOUNTING HOLE PATTERNS

STANDARD BASE

units: mm[inch]
tolerance: ± 0.1

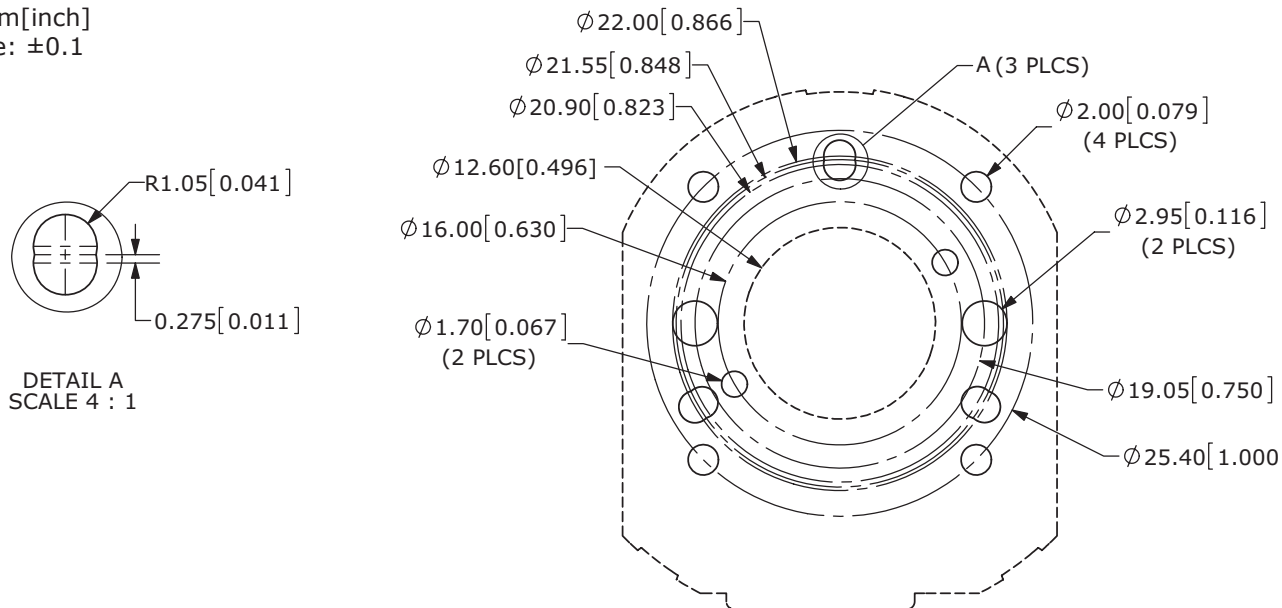

WIDE BASE

units: mm[inch]
tolerance: ± 0.1

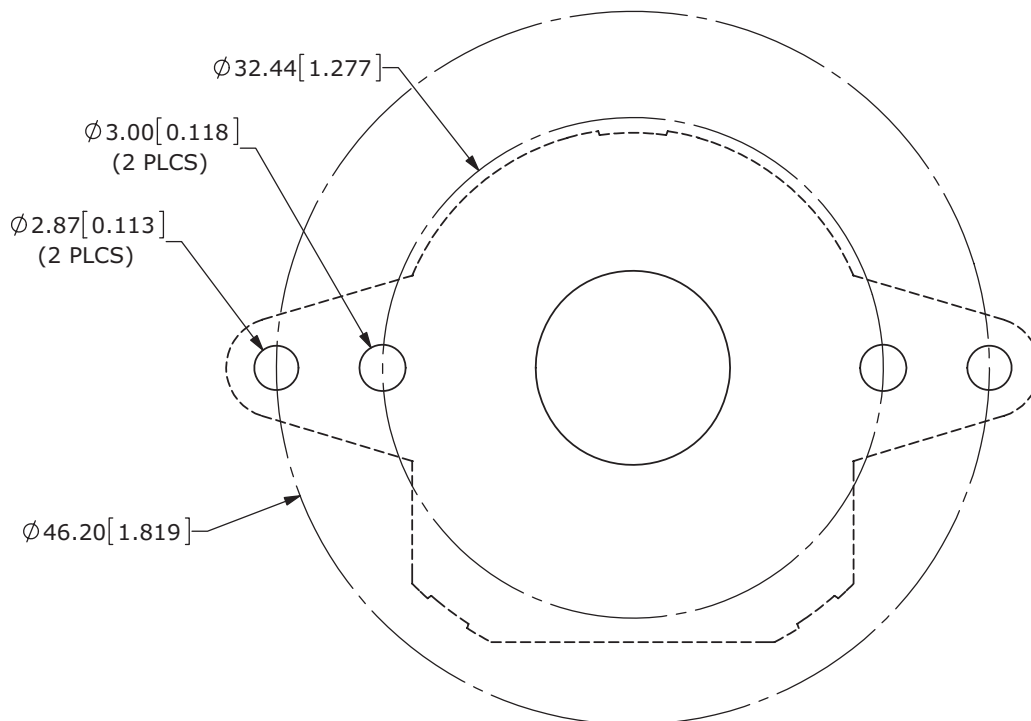

ASSEMBLY PROCEDURE

STEP 1

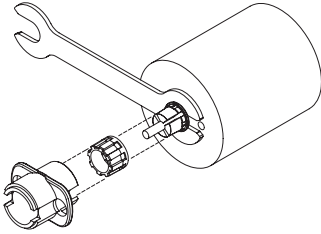

1. Insert Tool A as a spacer that defines the distance to the mounting surface.
2. Slide appropriate sized Sleeve over shaft all the way down to Tool A.
3. Slide Shaft Adaptor over Sleeve.
4. Use Tool C to press Shaft Adaptor over Sleeve [ensure Shaft Adaptor and Tool C spline alignment] until flush with Tool A.

STEP 2

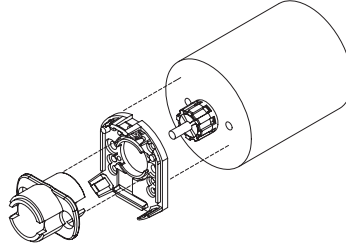

1. Remove Tools A and C.
2. Place Base on motor, with Tool C used as a centering tool.

STEP 3

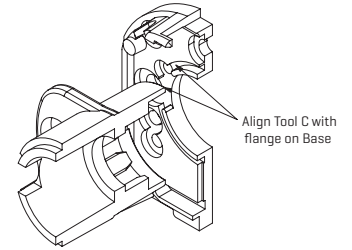

1. Align Tool C with flange on Base.
2. Slide Base and Tool C onto motor, centering onto the Shaft Adaptor.

STEP 4

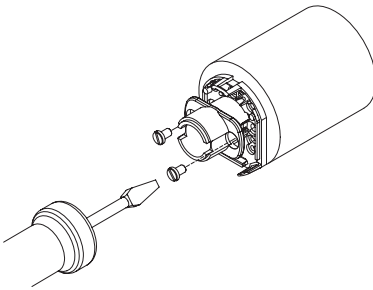

1. Fasten the Base on the motor (Tool C may need to be rotated to allow for some mounting configurations).
2. Remove Tool C.

STEP 5

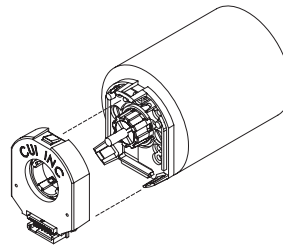

1. Snap the Top Cover onto the Base, carefully observing that the teeth of the Shaft Adaptor align with the grooves in the hub. *
- * We recommend no more than three cycles of mounting and removal of the AMT top cover base. Multiple cycles of mounting and removing the top cover can cause base fatigue over time and affect encoder performance.

STEP 6

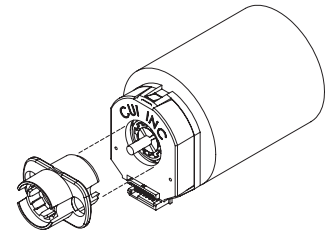

1. Make sure the snaps are fully engaged by pressing on the Hub with the reverse side of Tool C.
2. When assembly is finished, the Shaft Adaptor, Sleeve and Rotor Hub should all be flush with the Motor Shaft rotating freely.

APPLICATION NOTES

ENCODER OPERATIONAL MODE

- Initialization mode: At power up the encoder goes through an initiation and stabilization procedure. This includes microprocessor stabilization and the program for getting the absolute start position. This takes less than 100 milliseconds.
- Tracking mode:
 1. MCU 12 bit position register is updated from every 48 μ s.
 2. For accurate position information without the 48 μ s incremental outputs A/B can be used for tracking. These outputs are operational up to 8000 RPM without speed error.
 3. When using the incremental output there also is a Z index pulse that occurs once per turn.

SERIAL PERIPHERAL INTERFACE COMMANDS

The Serial Peripheral Interface (SPI) bus is a standard serial interface that operates in full duplex mode. It consists of 4 signals:

1. MOSI: Master Out Slave In
2. MISO: Master In Slave Out
3. SCK: Serial Clock
4. CSB: Chip Select (active low)

SPI BUS

The SPI bus transfers multiples of 8 bits in a frame. Data is captured on the rising edge of SCK and the output data is changed after the falling edge of SCK.

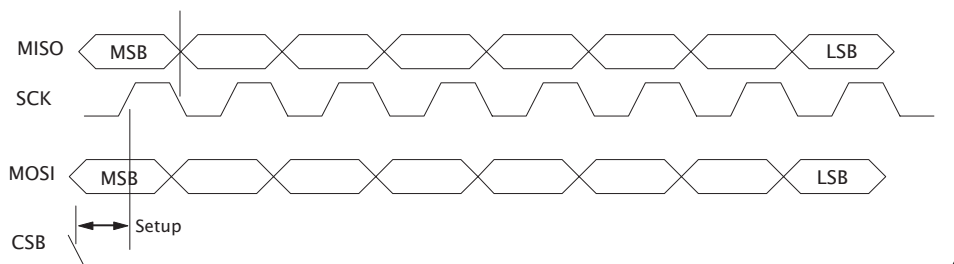

Terminology

MSB = most significant byte
 LSB = least significant byte
 msb = most significant bit
 lsb = least significant bit

Serial Peripheral Interface Bus (SPI) on AMT203 Timing Diagram
 (Figure 1)

The data out on MISO is valid once CSB goes low. The MOSI data is valid after the falling edge of SCK. The encoder drives data out on MISO for as long as CSB is low.

Normally, CSB goes low, then after 8 clock cycles the command is interpreted. CSB high resets the clock counter, and terminates any command sequence.

APPLICATION NOTES (CONTINUED)

SPI COMMANDS

All commands are 8 bits long. The msb is shifted in first, and is the leftmost bit shown in Figure 1.

Encoder Protocol Considerations:

The encoder is designed to operate with a high speed SPI link, in full duplex mode. This implies the host can issue commands and read data as quickly as necessary but there has to be an acknowledgement from the slave just before the data is transferred.

First the host will issue a command, then the encoder may respond with wait responses (0xA5) until ready. Once ready the encoder will echo the original command received from the master, followed by the requested data.

For example, to read the position the master will send the rd_pos command (0x10), it will then send no operation commands (nop_a5, 0x00) until it receives the original rd_pos command back. Once it receives the rd_pos response from the encoder, it knows that the next two bytes of data will be the MSB and the LSB respectively. To receive those two bytes the master will send two no operation commands.

It is recommended that the master leave a 20 μ s delay between reads to avoid extending the read time by forcing wait sequences.

Each byte transmitted must be followed by a release of the Chip Select line (CSB).

Command 0x00: nop_a5 (no operation)

This no operation command is ignored by the encoder and simply causes the next byte of data to be read. The encoder will respond with 0xA5 if there is no remaining data to be sent.

Command 0x10: rd_pos (read position)

This command causes a read of the current position.

To read position this sequence should be followed:

1. Master sends rd_pos command. Encoder responds with idle character.
2. Continue sending nop_a5 command while encoder response is 0xA5
3. If response was 0x10 (rd_pos), send nop_a5 and receive MSB position (lower 4 bits of this byte are the upper 4 of the 12-bit position)
4. Send second nop_a5 command and receive LSB position (lower 8 bits of 12-bit position)

Note that it is possible to overlap commands. For instance, instead of issuing nop_a5 for steps 3 and 4, you could begin another read position sequence since the position data is already in the buffer. The read and write FIFOs for the streams are 16 bytes long and it is up to the user to avoid overflow.

Command 0x70: set_zero_point (zero set)

This command sets the current position to zero and saves this setting in the EEPROM.

To set the zero point this sequence should be followed:

1. Send set_zero_point command
2. Send nop_a5 command while response is not 0x80
3. A response of 0x80 means that the zero set was successful and the new position offset is stored in EEPROM.
4. The encoder must be power cycled. If the encoder is not power cycled, the position values will not be calculated off the latest zero position. When the encoder is powered on next the new offset will be used for the position calculation.

REVISION HISTORY

| rev. | description | date |
|------|--|------------|
| 1.0 | initial release | 05/01/2010 |
| 1.01 | updated pin-out | 10/01/2010 |
| 1.02 | updated application note | 01/01/2011 |
| 1.03 | updated SPI commands | 09/16/2011 |
| 1.04 | addition of shock and incremental output current data, correction of vibration data, updated part number key | 09/30/2011 |
| 1.05 | updated Part Number Key | 03/09/2012 |
| 1.06 | updated tools | 07/13/2012 |
| 1.07 | added locking connector drawing | 02/12/2013 |
| 1.08 | updated spec | 12/09/2013 |
| 1.09 | updated spec | 11/19/2014 |
| 1.10 | updated spec | 05/13/2016 |

The revision history provided is for informational purposes only and is believed to be accurate.



CUI INC[®]

Headquarters
20050 SW 112th Ave.
Tualatin, OR 97062
800.275.4899

Fax 503.612.2383
cui.com
techsupport@cui.com

CUI offers a one (1) year limited warranty. Complete warranty information is listed on our website.

CUI reserves the right to make changes to the product at any time without notice. Information provided by CUI is believed to be accurate and reliable. However, no responsibility is assumed by CUI for its use, nor for any infringements of patents or other rights of third parties which may result from its use.

CUI products are not authorized or warranted for use as critical components in equipment that requires an extremely high level of reliability. A critical component is any component of a life support device or system whose failure to perform can be reasonably expected to cause the failure of the life support device or system, or to affect its safety or effectiveness.