

REV.	DESCRIPTION	DATE
A	NEW DRAWING	9/15/2008

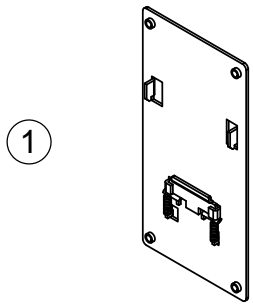

DIN RAIL BRACKET
QTY: 1

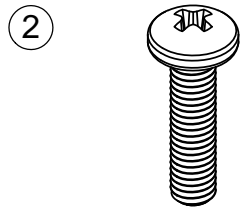

M3X0.5
12mm length
QTY: 4

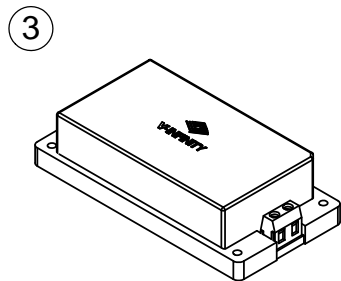

V-INFINITY
AC/DC CONVERTER
QTY: 1
(sold separately)

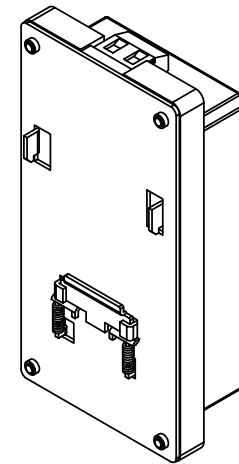
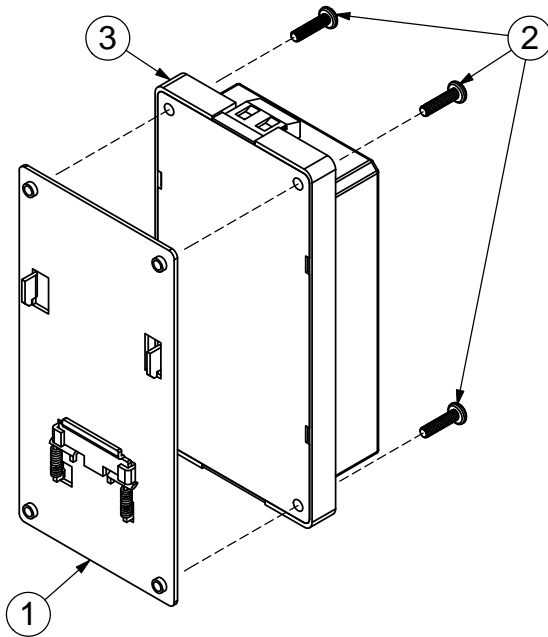

TITLE: DIN RAIL MOUNTING BRACKET ASSEMBLY INSTRUCTIONS		REV: A
PART NO. FSC-S30-DIN	UNITS: MM [INCHES]	
DRAWN BY: ZRJ	APPROVED BY:	SCALE: 1:2

REV.	DESCRIPTION	DATE
A	NEW DRAWING	9/15/2008

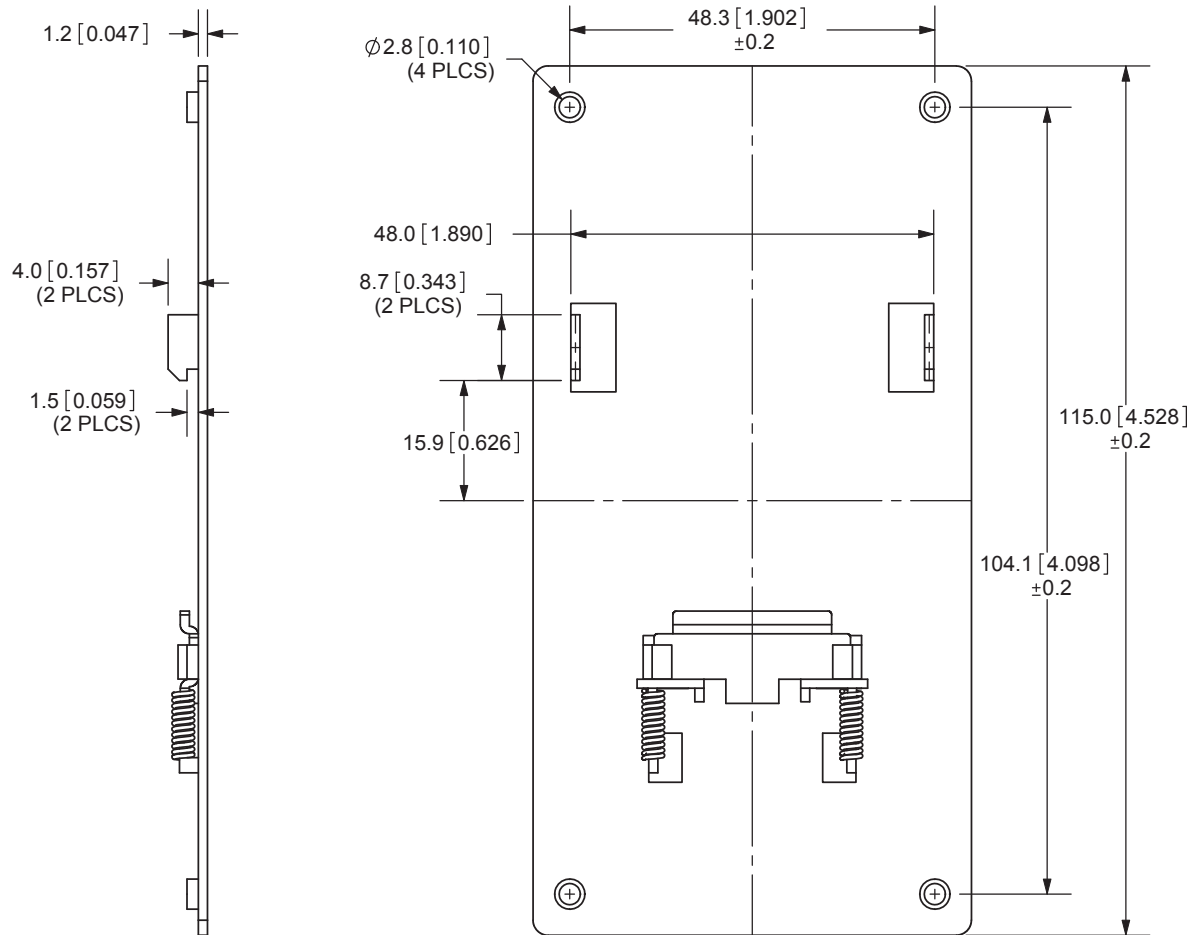

TOLERANCE:
±0.3mm UNLESS OTHERWISE
SPECIFIED



20050 SW 112th Ave.
Tualatin, OR 97062
Phone: 503-612-2300
800-275-4899
Fax: 503-612-2383
Website: www.cui.com

TITLE: DIN RAIL MOUNTING BRACKET ASSEMBLY INSTRUCTIONS		REV: A
PART NO: DIN RAIL BRACKET	UNITS: MM [INCHES]	
DRAWN BY: ZRJ	APPROVED BY:	SCALE: 1:1