

SERIES: SD | **DESCRIPTION:** STANDARD DIN CONNECTOR

FEATURES

- strain relief
- 3~13 pins
- 100 Vac rated



PART NUMBER KEY

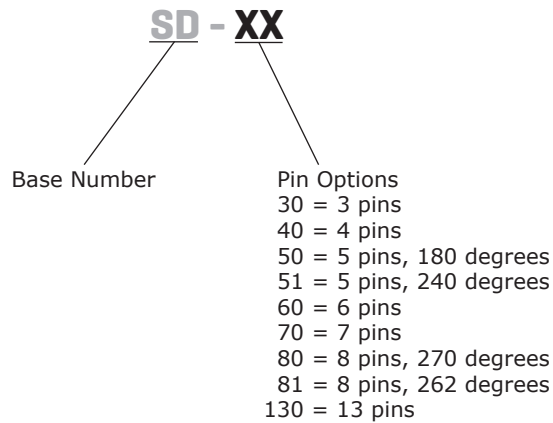

SPECIFICATIONS

parameter	conditions/description	min	typ	max	units
rated input voltage			100 12		Vac Vdc
rated input current	at 100 Vac at 12 Vdc			1 2	A A
contact resistance				30	mΩ
insulation resistance	at 500 Vdc	100			MΩ
voltage withstand	for 1 minute			1,000	Vac
insertion force				4	kg
withdrawal force		1		3.5	kg
operating temperature		5		70	°C
life			5,000		cycles
RoHS	2011/65/EU				

MECHANICAL DRAWINGS

units: mm[inches]
tolerance: ± 0.1 mm

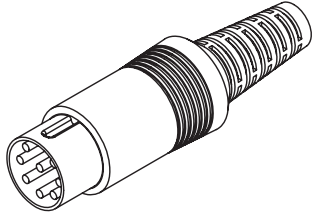

	MATERIAL	PLATING
contact pins (30~80)	brass	nickel
contact pins (81, 130)	brass	silver
shell	steel	nickel
insulator (30~80, 130)	PBT	
insulator (81)	ABS	
boot	EVA	

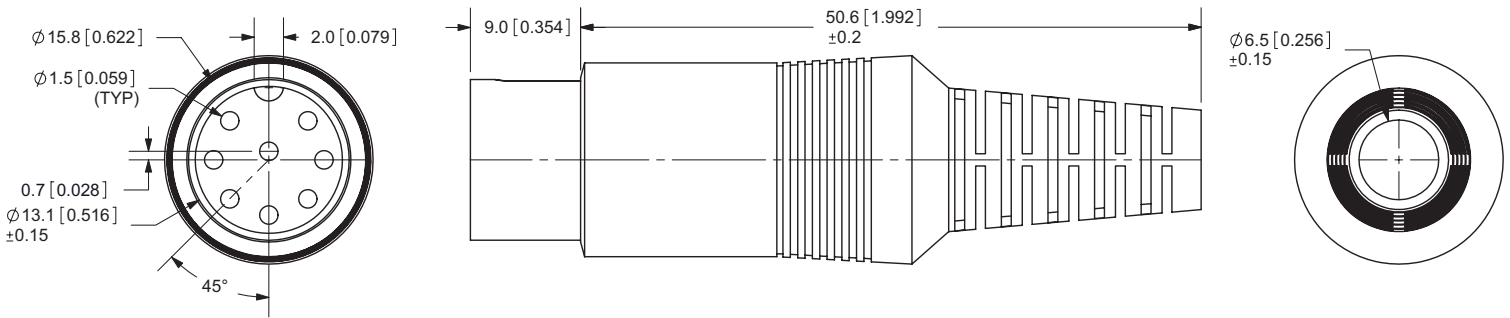

SD-30

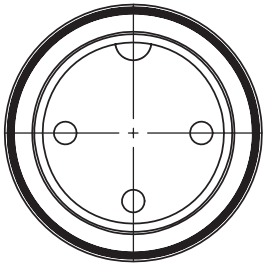

SD-40

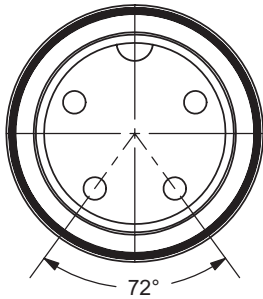

SD-50

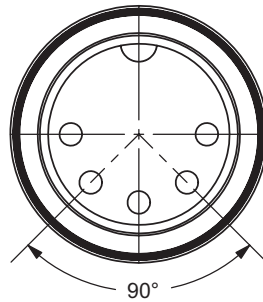

SD-51

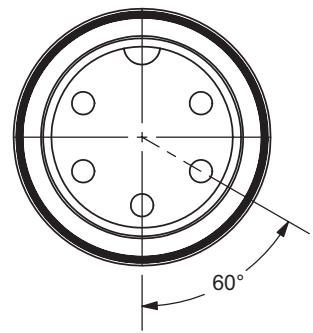

SD-60

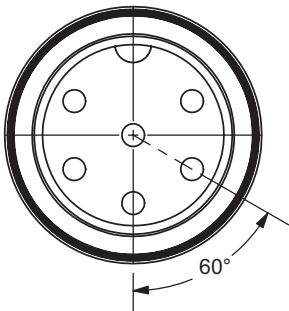

SD-70

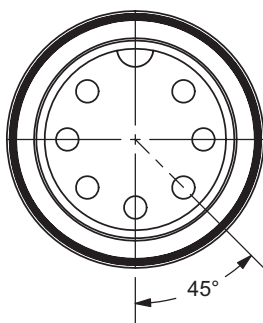

SD-80

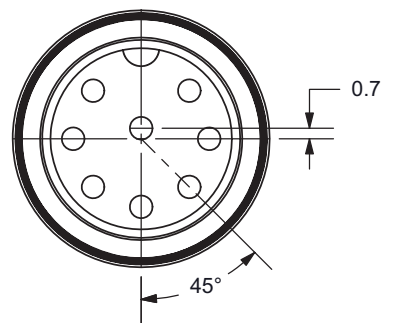

units: mm[inches]
tolerance: ±0.1 mm

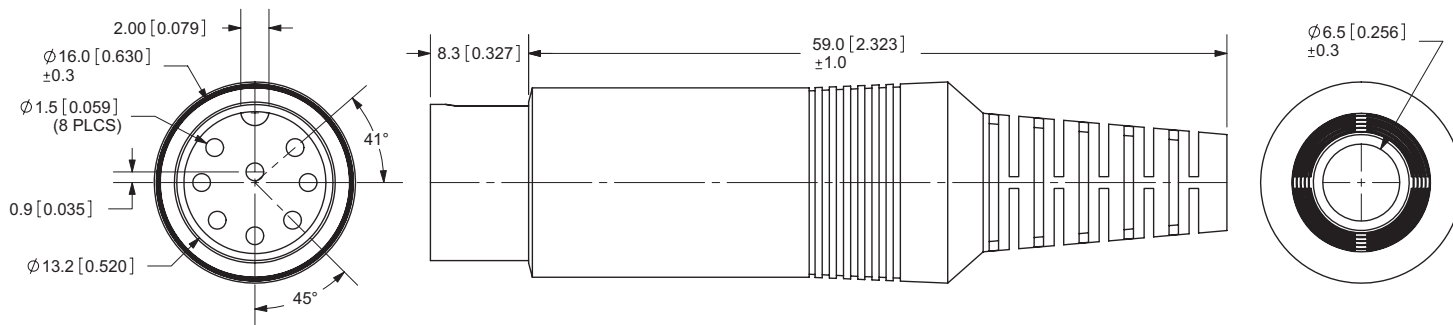
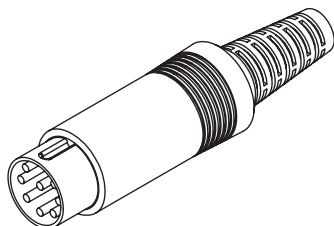

SD-81

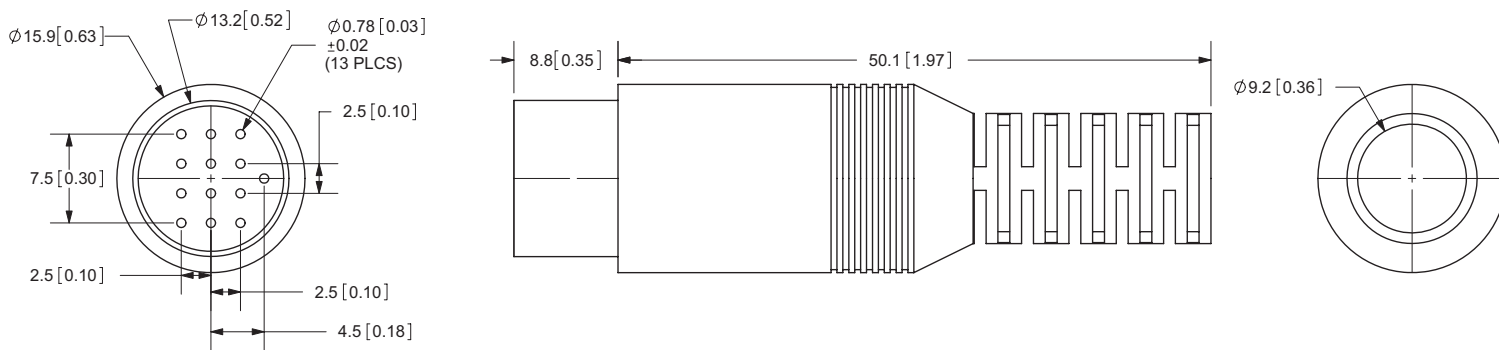
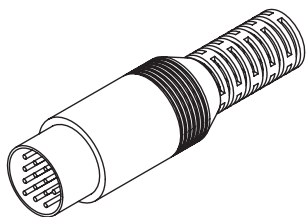

SD-130

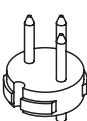

MECHANICAL ASSEMBLY

1	cover	
2	metal shield	
3	housing	

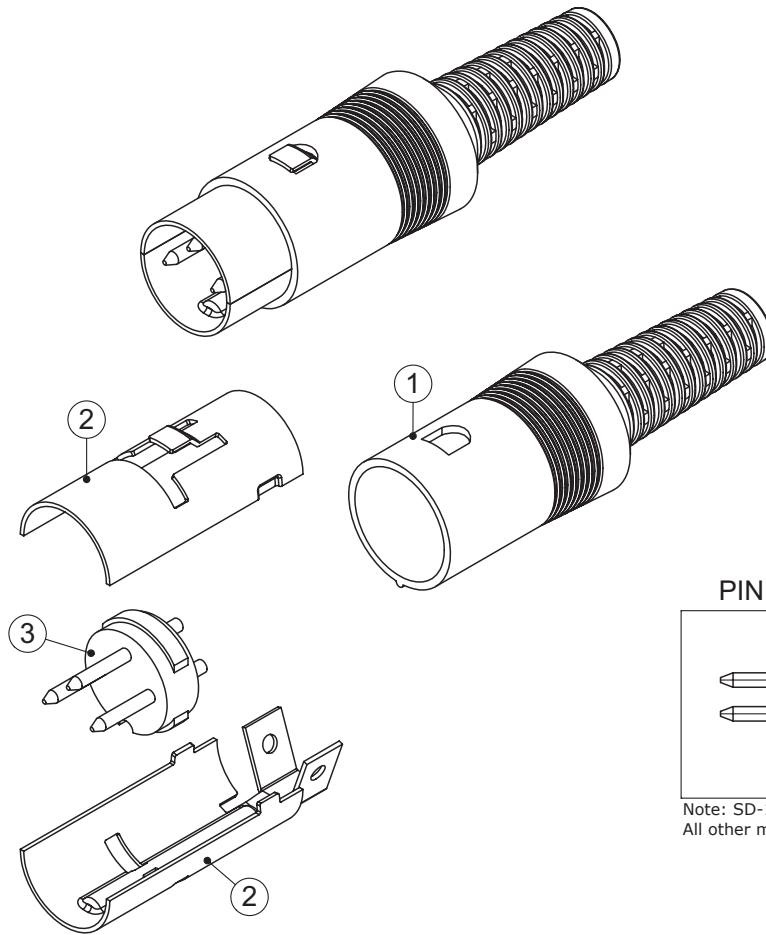

PIN DETAILS

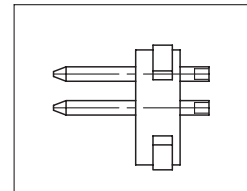

Note: SD-130 has solid solder pins.
All other models have solder cups.

STEP 1
solder wires to
housing (3),
assemble metal
shield pieces (2)
onto housing (3)

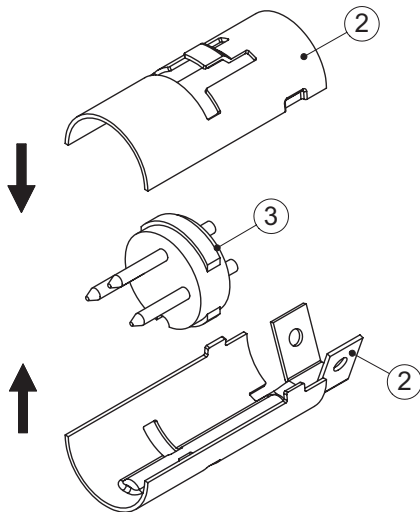

STEP 2
slide cover (1)
over metal shield (2)

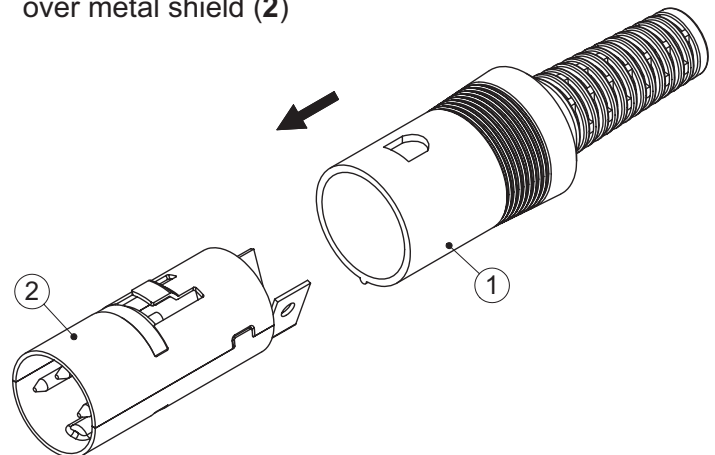

REVISION HISTORY

rev.	description	date
1.0	initial release	02/23/2006
1.01	new template applied	02/15/2012
1.02	updated housings	04/12/2012
1.03	corrected center pin positioning on SD-80	09/13/2013
1.04	updated datasheet	05/22/2017

The revision history provided is for informational purposes only and is believed to be accurate.



Headquarters
20050 SW 112th Ave.
Tualatin, OR 97062
800.275.4899

Fax 503.612.2383
cui.com
techsupport@cui.com

CUI offers a one (1) year limited warranty. Complete warranty information is listed on our website.

CUI reserves the right to make changes to the product at any time without notice. Information provided by CUI is believed to be accurate and reliable. However, no responsibility is assumed by CUI for its use, nor for any infringements of patents or other rights of third parties which may result from its use.

CUI products are not authorized or warranted for use as critical components in equipment that requires an extremely high level of reliability. A critical component is any component of a life support device or system whose failure to perform can be reasonably expected to cause the failure of the life support device or system, or to affect its safety or effectiveness.