

SERIES: UJ31-CH-SMT | **DESCRIPTION:** USB RECEPTACLE

FEATURES

- USB Type C receptacle
- USB 3.1
- 10 Gbit/s data transfer speed
- reflow solder compatible
- tape & reel packaging



PART NUMBER KEY

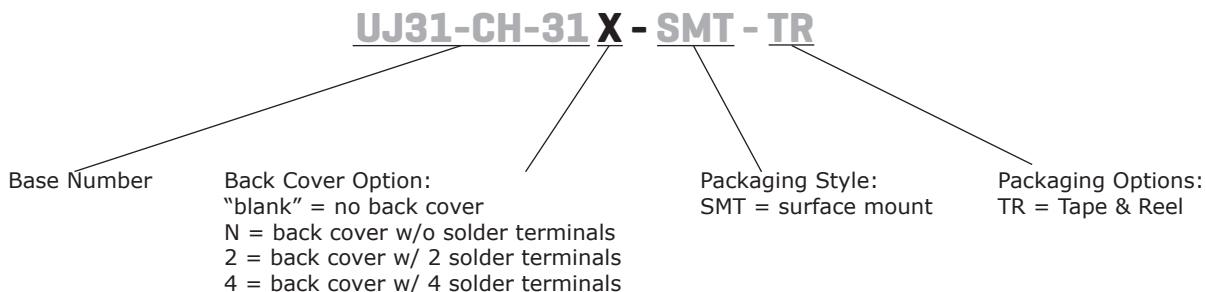

SPECIFICATIONS

parameter	conditions/description	min	typ	max	units
rated input voltage				20	Vdc
rated input current	as per EIA-364-70, Method B				
	power pins collectively (A4, A9, B4, B9)			5.0	A
	GND pins collectively (A1, A12, B1, B12)			6.25	A
	VCONN pins individually (A5, B5)			1.25	A
	all other signal pins individually			0.25	A
contact resistance ¹	between terminals and mating plug			40	mΩ
insulation resistance	at 100 Vdc for 1 minute between adjacent contacts	100			MΩ
voltage withstand	at 60 Hz for 1 minute between adjacent contacts			100	Vac
insertion force	at a rate of 12.5 mm/min	5		20	N
withdrawal force	at a rate of 12.5 mm/min	8		20	N
life	at a rate of 200 max cycles per hour		10,000		cycles
operating temperature		-30		85	°C
storage temperature		-40		85	°C
flammability rating	UL94V-0				
RoHS	2011/65/EU				

Note: 1. When measured at 20 mV max / 100 mA.

MECHANICAL DRAWING

units: mm
 tolerance:
 X.X ±0.20 mm
 X.XX ±0.15 mm

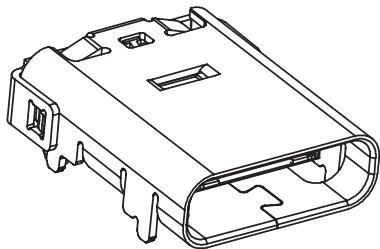

	MATERIAL	PLATING
contact terminals	copper alloy	contact: 2 μ" gold solder: tin
shell	stainless steel	nickel
EMI shell	stainless steel	
mid plate	stainless steel	tin
insulator	PA9T	

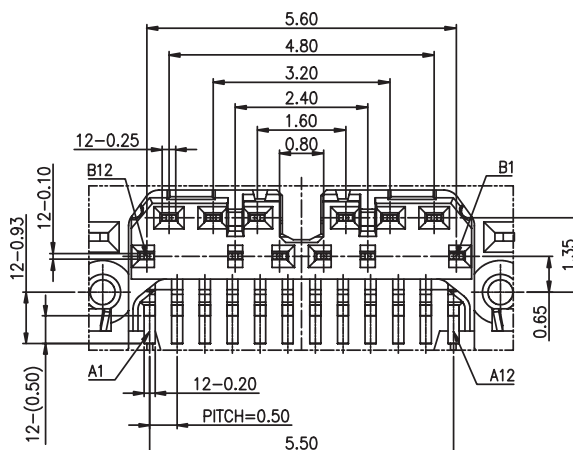
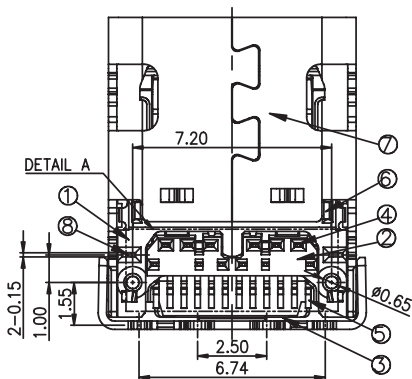
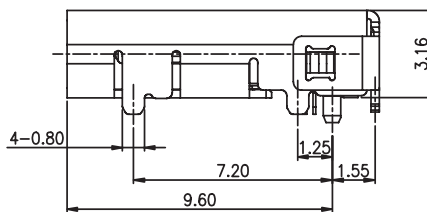
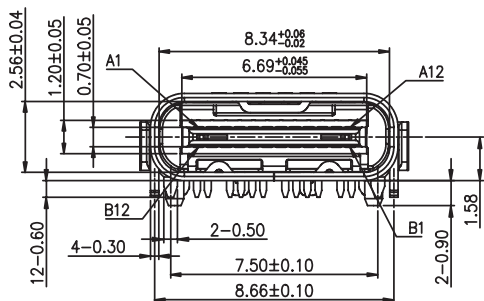
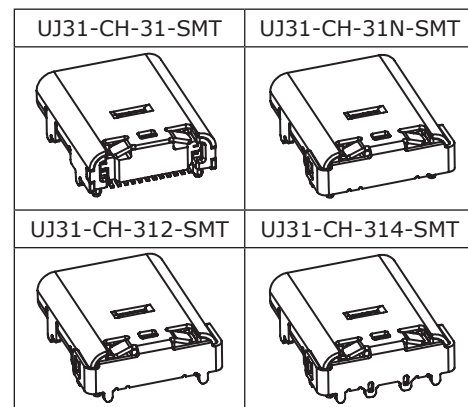
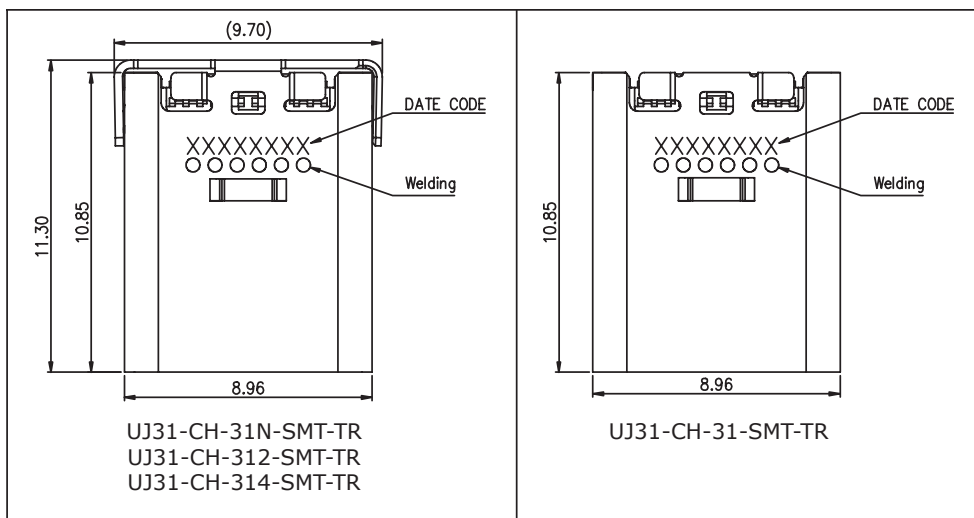

DETAIL A
 SCALE: 8/1

MECHANICAL DRAWING (CONTINUED)

units: mm
PCB tolerance: ± 0.05 mm

PIN CONNECTIONS					
PIN	SIGNAL NAME	MATING SEQUENCE	PIN	SIGNAL NAME	MATING SEQUENCE
A1	GND	FIRST	B12	GND	FIRST
A2	SSTXp1	SECOND	B11	SSRXp1	SECOND
A3	SSTXn1	SECOND	B10	SSRXn1	SECOND
A4	V _{BUS}	FIRST	B9	V _{BUS}	FIRST
A5	CC1	SECOND	B8	SBU2	SECOND
A6	Dp1	SECOND	B7	Dn2	SECOND
A7	Dn1	SECOND	B6	Dp2	SECOND
A8	SBU1	SECOND	B5	CC2	SECOND
A9	V _{BUS}	FIRST	B4	V _{BUS}	FIRST
A10	SSRXn2	SECOND	B3	SSTXn2	SECOND
A11	SSRXp2	SECOND	B2	SSTXp2	SECOND
A12	GND	FIRST	B1	GND	FIRST
SHELL		GND	SHELL		GND

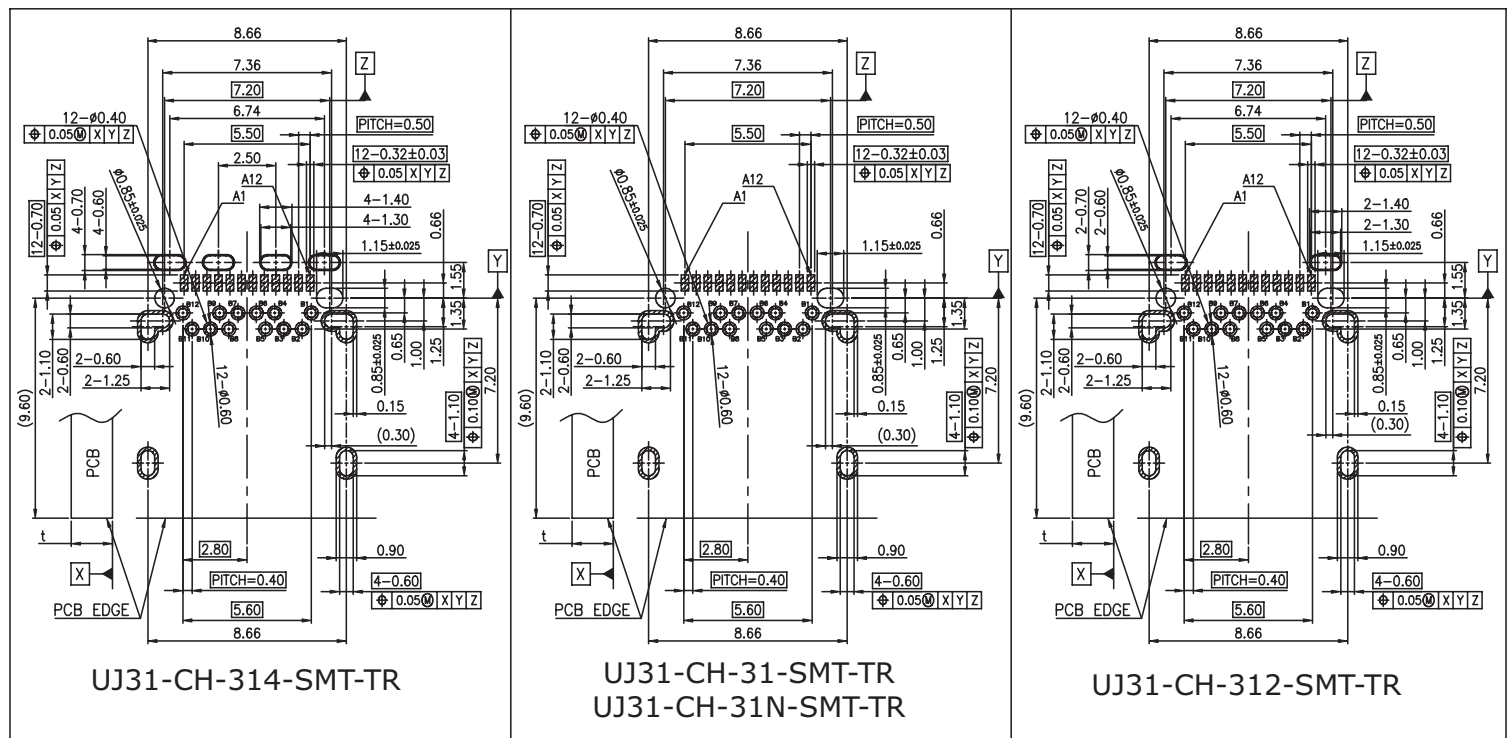

Recommended PCB Layout
Top View

SOLDERABILITY

parameter	conditions/description	min	typ	max	units
reel storage	at relative humidity <60%			30	°C
reflow soldering ¹	see reflow profile	255	260	265	°C

Note: 1. It is recommended to reflow solder within 168 hours from opening vacuum packaging at a temperature <30°C & relative humidity <60%.

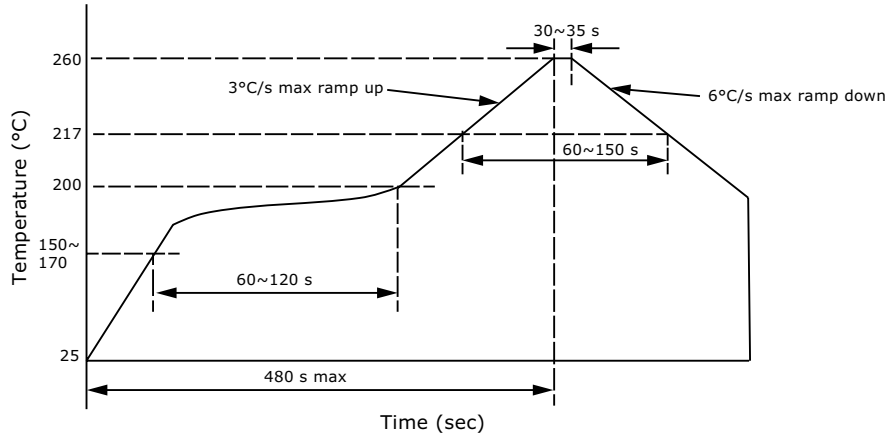

PACKAGING

units: mm

Reel Size: Ø380 mm

Reel QTY: 1,200 pcs per reel

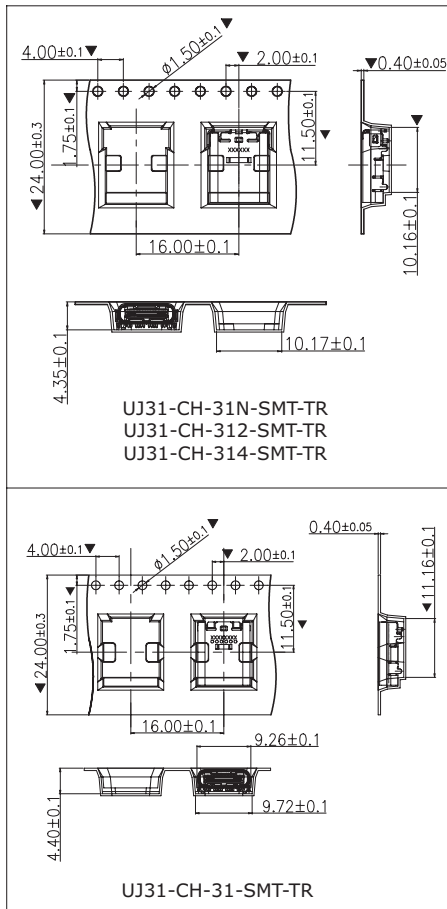

NOTICE:

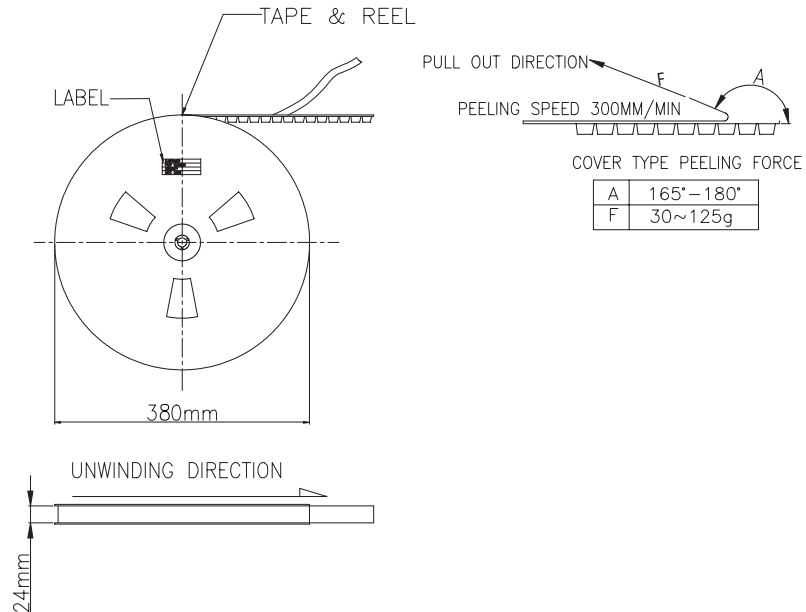
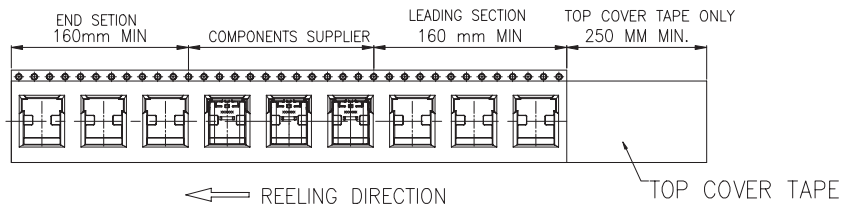

REVISION HISTORY

rev.	description	date
1.0	initial release	12/19/2017
1.01	updated reel details	01/19/2018
1.02	updated datasheet	01/30/2018

The revision history provided is for informational purposes only and is believed to be accurate.



CUI INC[®]

Headquarters
20050 SW 112th Ave.
Tualatin, OR 97062
800.275.4899

Fax 503.612.2383
cui.com
techsupport@cui.com

CUI offers a one (1) year limited warranty. Complete warranty information is listed on our website.

CUI reserves the right to make changes to the product at any time without notice. Information provided by CUI is believed to be accurate and reliable. However, no responsibility is assumed by CUI for its use, nor for any infringements of patents or other rights of third parties which may result from its use.

CUI products are not authorized or warranted for use as critical components in equipment that requires an extremely high level of reliability. A critical component is any component of a life support device or system whose failure to perform can be reasonably expected to cause the failure of the life support device or system, or to affect its safety or effectiveness.