

**PART NUMBER:** EPA090050-P5-SZ**DESCRIPTION:** linear adapter**SPECIFICATIONS**

output voltage	9 V ac at 500 mA	
rated input voltage	120 V ac	
primary rated voltage	120 V ac 60 Hz 8 W	
primary exciting current	30 mA rms max.	
secondary rated voltage & current	no load voltage (max.)	11 V
	full load voltage (500 mA)	9 V $\pm$ 5%
temperature rise of primary winding (full load)	70°C max. using resistance method	
insulation resistance	$\geq$ 100 M Ohm at 500 Vdc	
HI-POT test	primary to secondary	1240 V ac at 2 mA for 1 minute
	primary to secondary	1600 V ac at 2 mA for 1 second
	primary winding to secondary winding	1600 V ac at 2 mA for 1 second
	primary winding to core	1600 V ac at 2 mA for 1 second
	secondary winding to core	750 V ac at 2 mA for 1 second
safety standard	UL/cUL	
RoHS compliant	yes	
weight	218 g	
test conditions	ambient temp	40 $\pm$ 2°C
	humidity	90~95% 96 hours at Full Load
	rated voltage	8 hours at full load
adapter color	case	black
	cord	black

**PART NUMBER:** EPA090050-P5-SZ

**DESCRIPTION:** linear adapter

**LABEL**

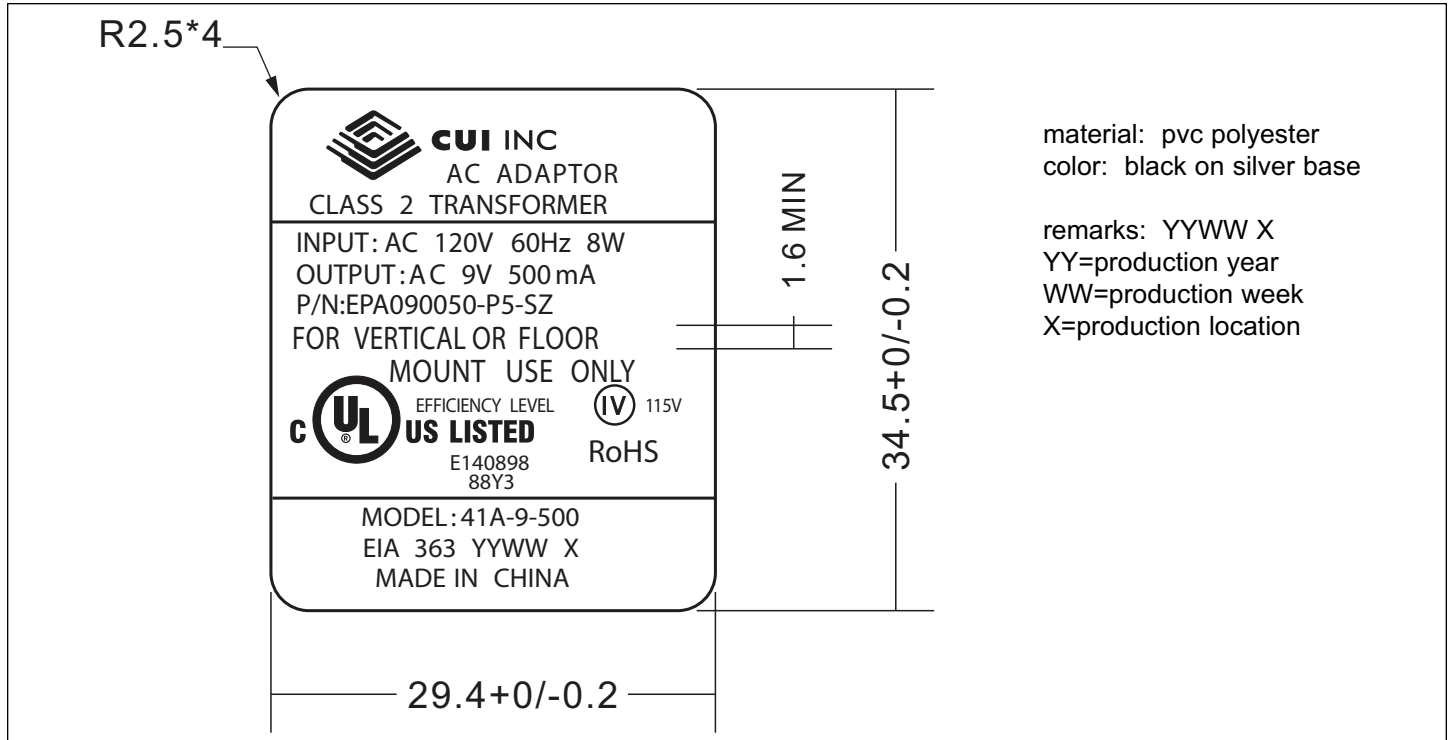

**PART NUMBER:** EPA090050-P5-SZ

**DESCRIPTION:** linear adapter

**CIRCUIT DIAGRAM**

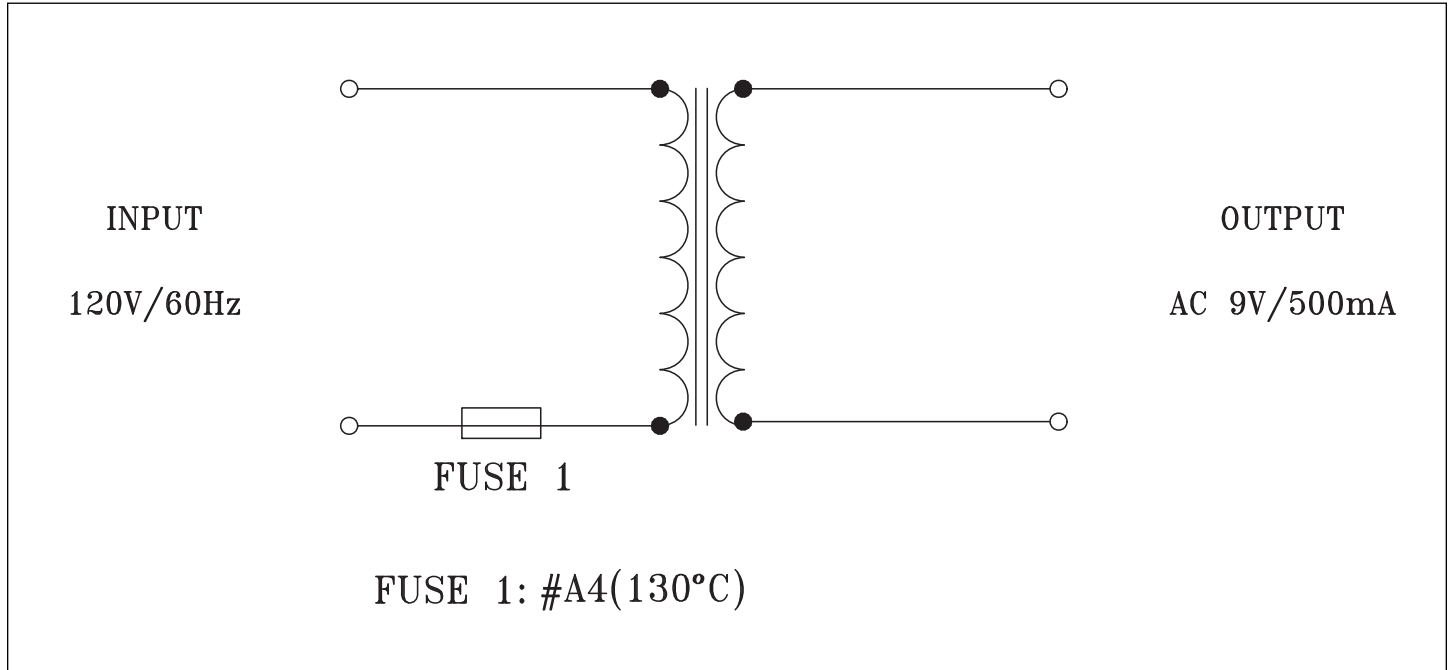

**TEST CIRCUIT**

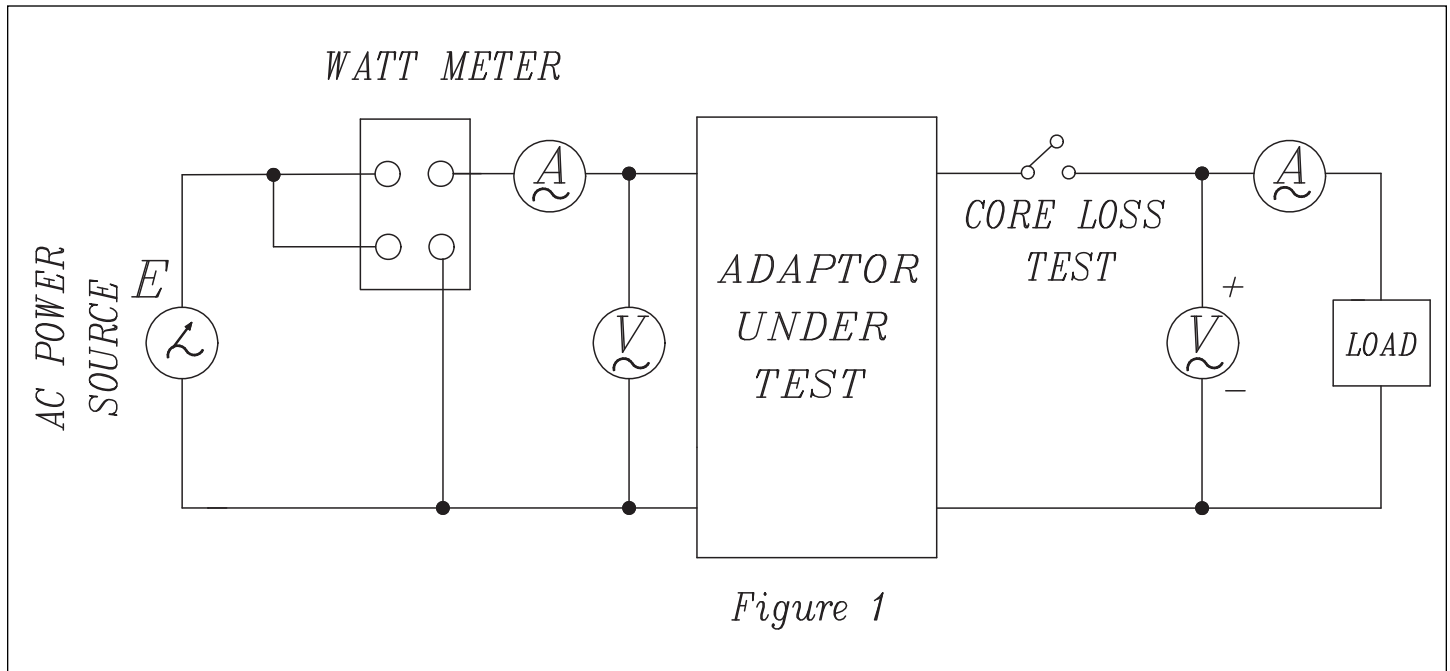

**PART NUMBER:** EPA090050-P5-SZ

**DESCRIPTION:** linear adapter

**MECHANICAL DRAWING**

weight	218 g
tolerance	±1mm

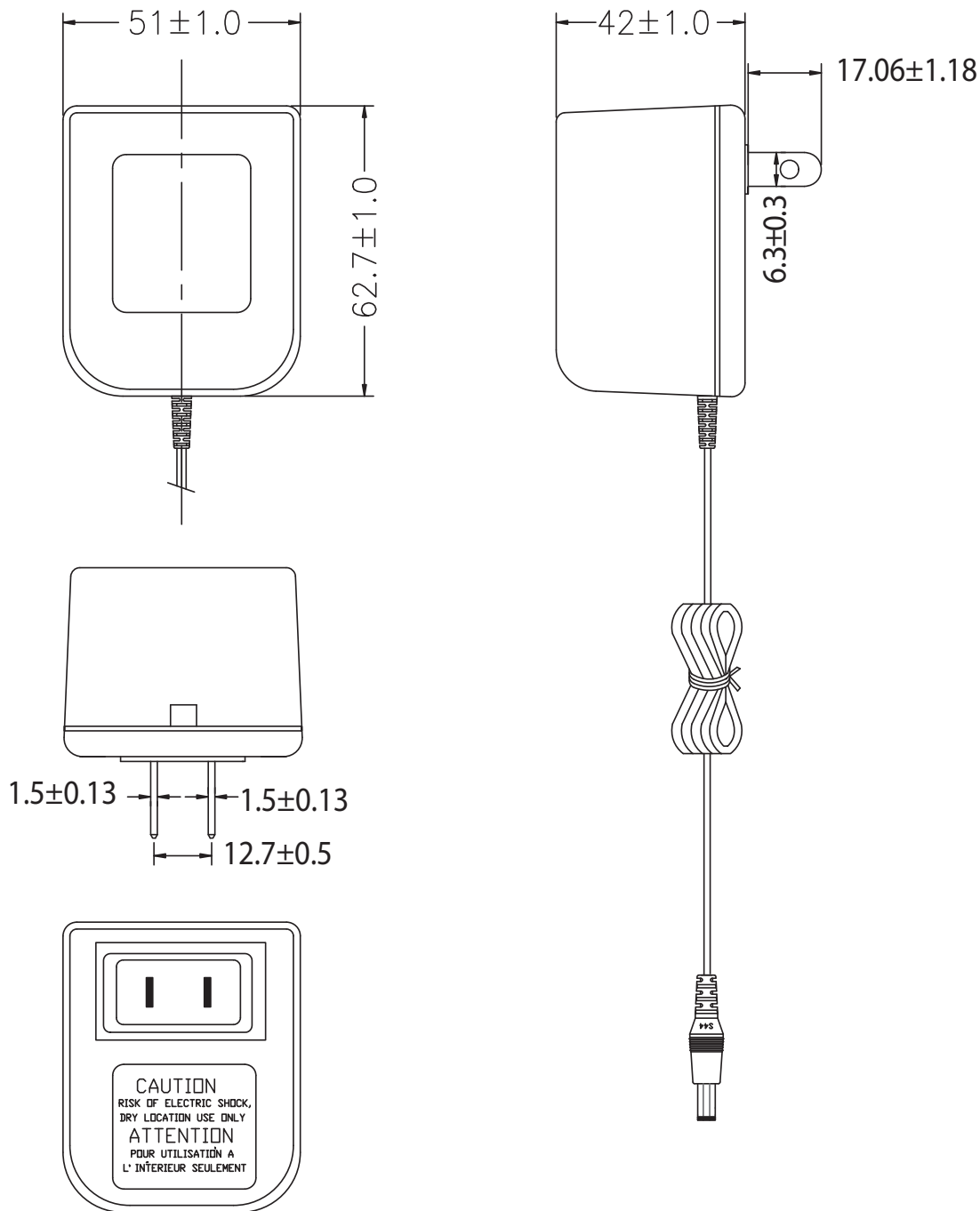

**PART NUMBER:** EPA090050-P5-SZ

**DESCRIPTION:** linear adapter

**DC CORD**

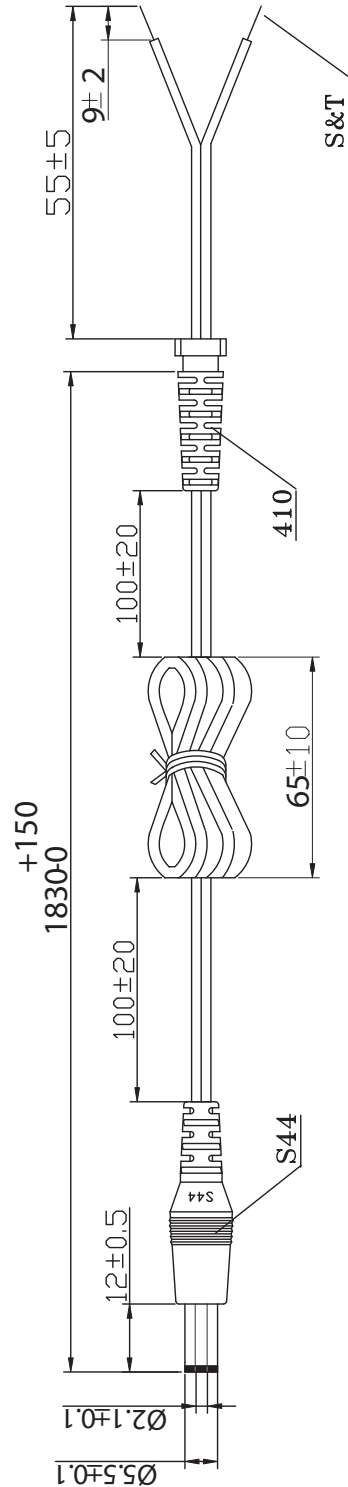

#24AWG X2C UL2468 HAVE ON WORD WIRE IN OUTER, NO WORD WIRE IN INNER

WIRE OD: Ø 1.5X3.0

VIBRATION TEST	Parameter request
	a. ±60° b. WEIGHT 200g c. 40 ROUND/MINUTE d. OVER 1000 COUNT MIN

**PART NUMBER:** EPA090050-P5-SZ

**DESCRIPTION:** linear adapter

**INDIVIDUAL PACKAGING**

tolerance:  $\pm 1$

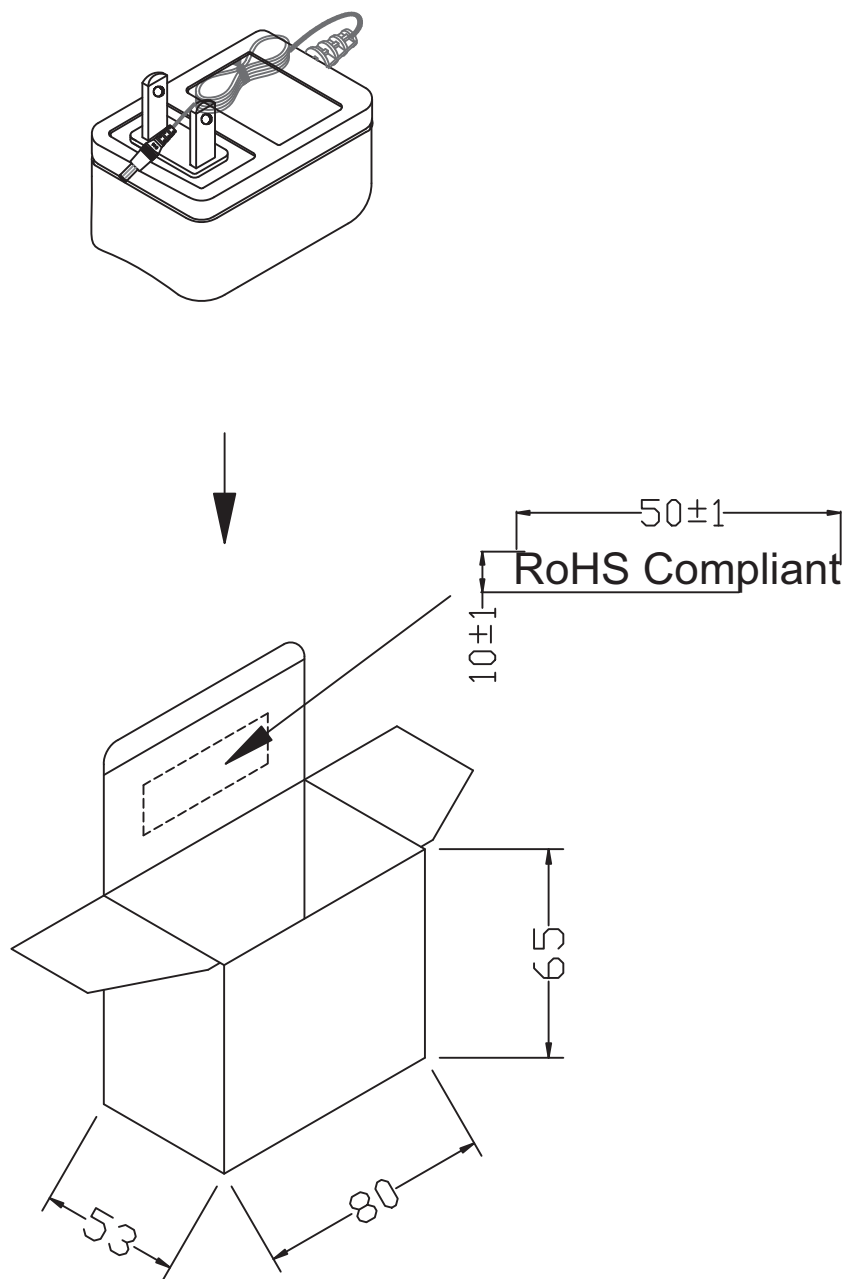

**PART NUMBER:** EPA090050-P5-SZ

**DESCRIPTION:** linear adapter

**PACKAGING**

tolerance: +7/-0

OUTSIDE CARTON:A=B(6mm)

INSIDE CARTON:B3B(3mm)

CARTON SIZE: 350X345X190mm

Q'TY: 60pcs(20x3x1)

