

MODEL: CSS-95B30-SMT | **DESCRIPTION:** MAGNETIC BUZZER TRANSDUCER

FEATURES

- surface mount
- side sound port
- externally driven



SPECIFICATIONS

parameter	conditions/description	min	typ	max	units
rated voltage	Vo-p 		5		Vo-p
operating voltage		4		7	Vo-p
current consumption	at rated voltage, 2,700 Hz square wave, 1/2 duty			80	mA
rated frequency			2,700		Hz
sound pressure level	at 10 cm (A-weight), rated voltage, 2,700 Hz square wave, 1/2 duty	92	95		dBa
coil resistance		27	30	33	Ω
dimensions	10 x 10 x 3.2				mm
weight			0.8		g
material	L.C.P. (black)				
terminal	SMT type (Sn plating)				
operating temperature		-20		70	°C
storage temperature		-40		85	°C
RoHS	yes				

Note: Add suffix "-TR" to the model for tape & reel packaging

SOLDERABILITY

parameter	conditions/description	min	typ	max	units
reflow soldering	see reflow solder profile			260	°C

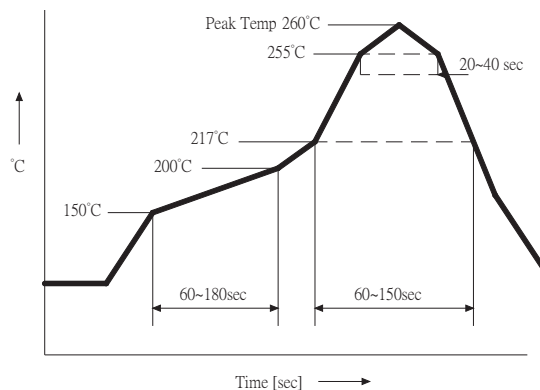

MECHANICAL DRAWING

units: mm

tolerance: ± 0.3 mm

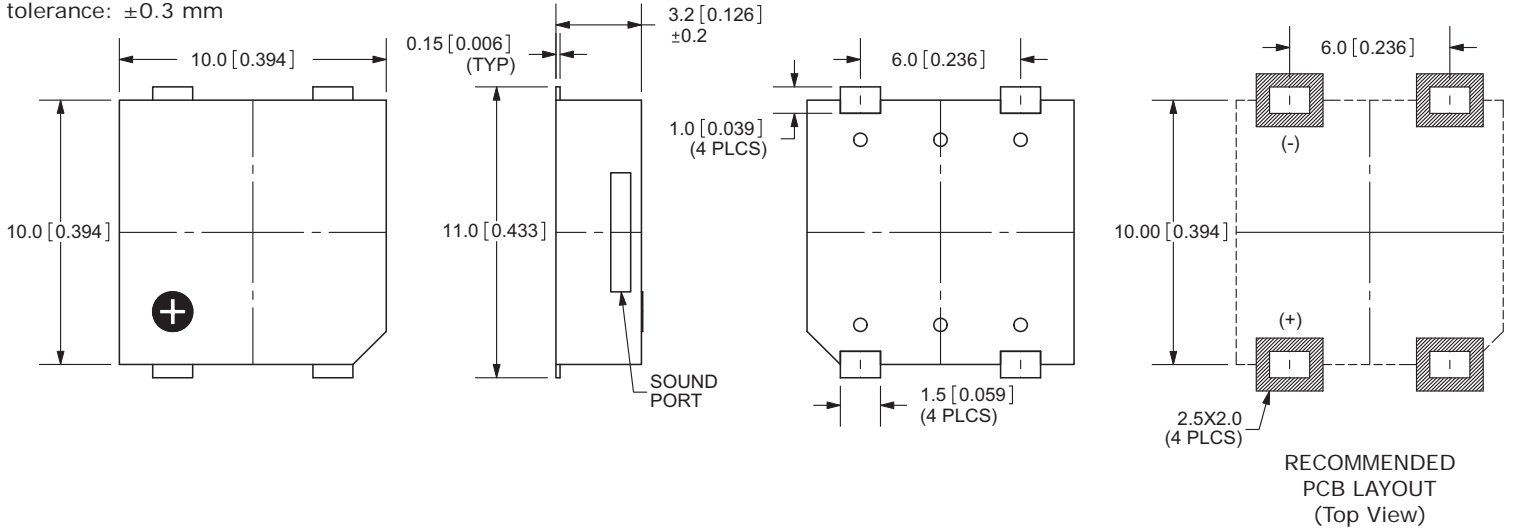

FREQUENCY RESPONSE CURVE

A: Frequency Response. Magn dB re 20.00uPA

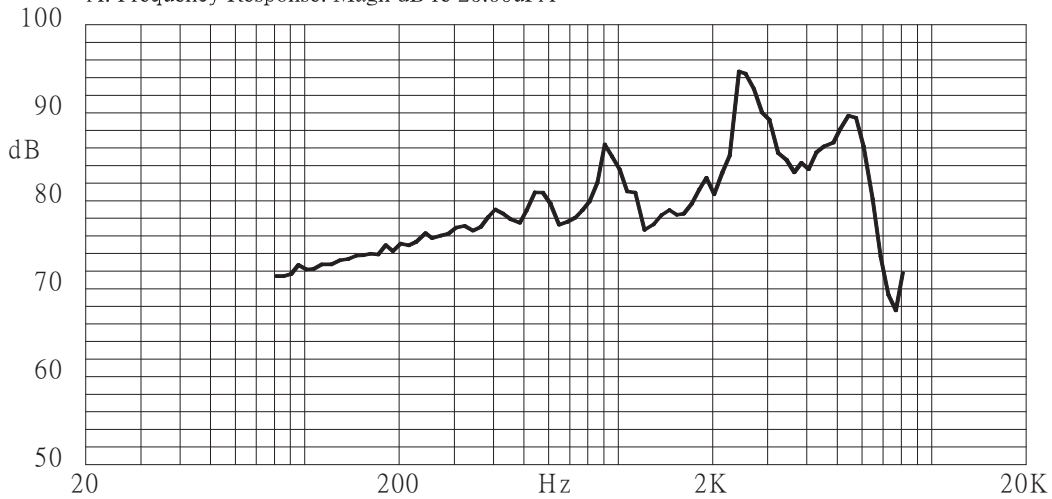

MEASUREMENT METHOD

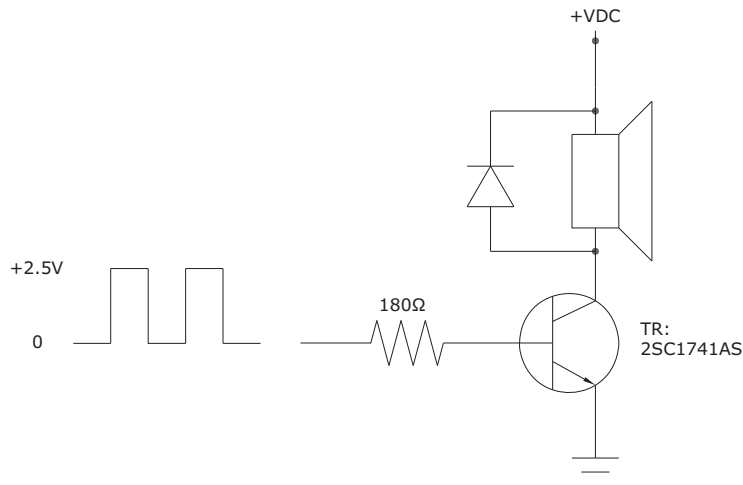

REVISION HISTORY

rev.	description	date
1.0	initial release	07/13/2010
1.01	updated part number, added TR package option, applied new spec template	05/03/2013

The revision history provided is for informational purposes only and is believed to be accurate.



CUI INC[®]

Headquarters
20050 SW 112th Ave.
Tualatin, OR 97062
800.275.4899

Fax 503.612.2383
cui.com
techsupport@cui.com

CUI offers a one (1) year limited warranty. Complete warranty information is listed on our website.

CUI reserves the right to make changes to the product at any time without notice. Information provided by CUI is believed to be accurate and reliable. However, no responsibility is assumed by CUI for its use, nor for any infringements of patents or other rights of third parties which may result from its use.

CUI products are not authorized or warranted for use as critical components in equipment that requires an extremely high level of reliability. A critical component is any component of a life support device or system whose failure to perform can be reasonably expected to cause the failure of the life support device or system, or to affect its safety or effectiveness.