



Part No: CST-951AP

Description: magnetic buzzer

Date: 1/30/2006

Unit: mm

Page No: 1 of 4

### SCOPE

This specification applies to magnetic buzzer, CST-951AP

### SPECIFICATION

No.	Item	Unit	Specification	Condition
1	Rated Voltage	Vo-p	5.0	
2	Operating Volt.	Vo-p	4.0~6.0	
3	Mean Current	mA	Max.80	Applying rated voltage,2730Hz square wave, 1/2duty
4	Coil Resistance	$\Omega$	$30 \pm 4.5$	
5	Sound Output	dBA	Min.85 (Typical 92)	Distance at 10cm(A-weight free air). Applying rated voltage 2730Hz,square wave, 1/2duty
6	Rated Frequency	Hz	2730	
7	Operating Temp.	$^{\circ}\text{C}$	-20 ~ +70	
8	Storage Temp.	$^{\circ}\text{C}$	-30 ~ +80	
9	Dimension	mm	$\phi 9.0 \times H4.5$	See attached drawing.
10	Weight	gram	0.6	
11	Material		PPO	
12	Terminal		Pin type (Plating Au)	See attached drawing.
13	Environmental Protection Regulation		RoHS	

### TYPICAL FREQUENCY RESPONSE CURVE

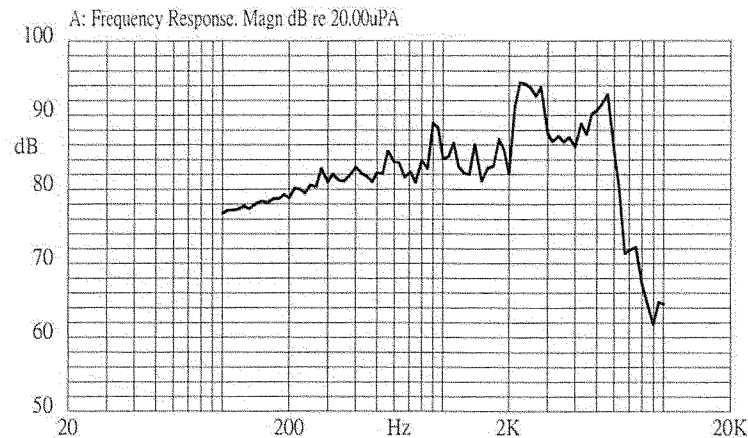

### APPEARANCE DRAWING

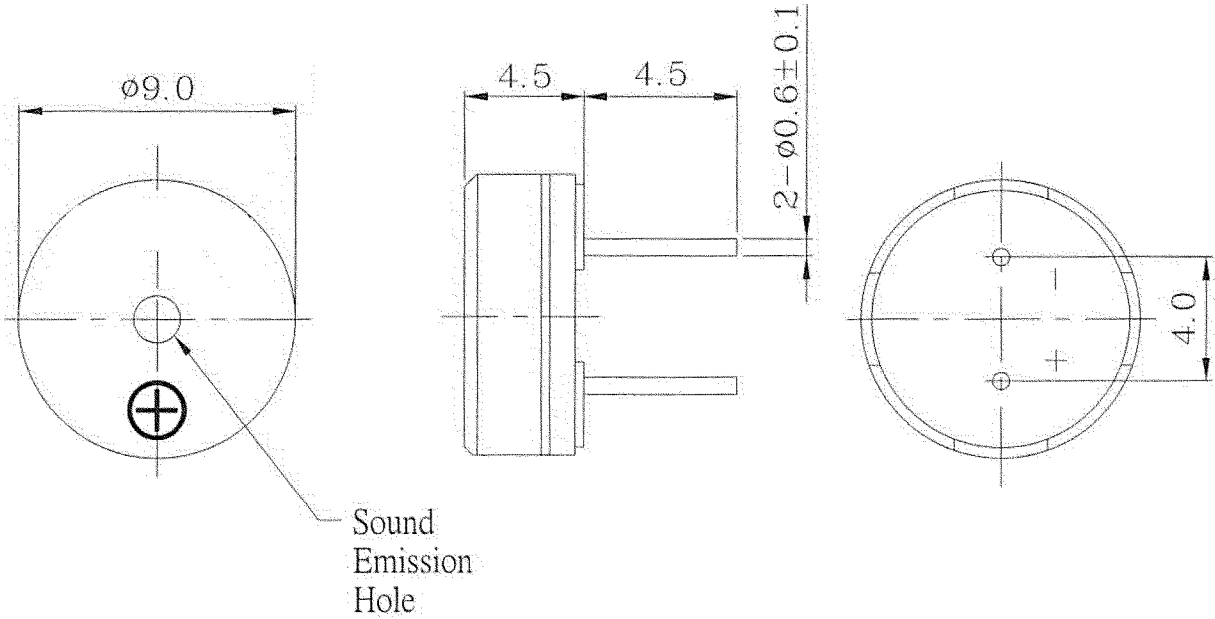

Tol :  $\pm 0.5$

Unit : mm

### MEASUREMENT METHOD

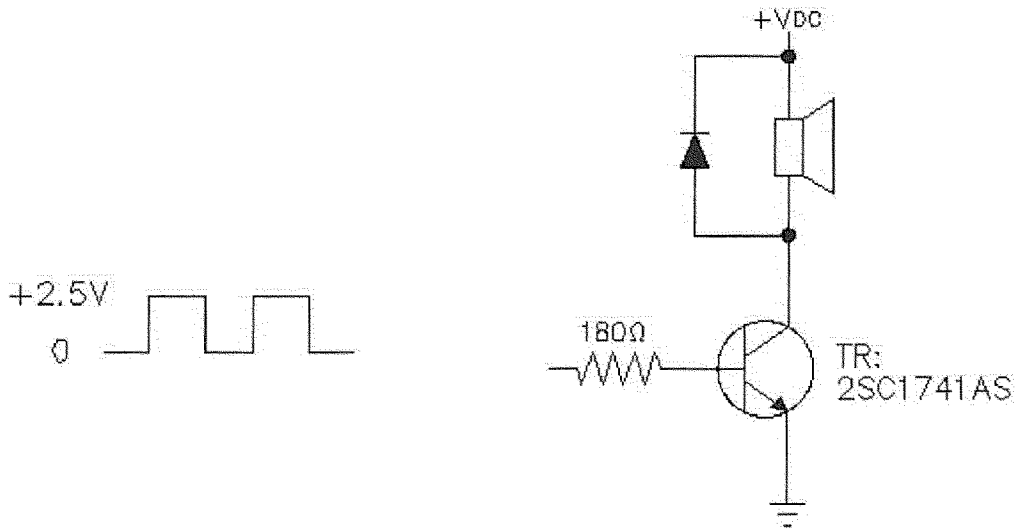



Part No: CST-951 AP

Description: magnetic buzzer

Date: 1/30/2006

Unit: mm

Page No: 3 of 4

### MECHANICAL CHARACTERISTICS

No.	Item	Test condition	Evaluation standard
1	Solderability <sup>1</sup>	Lead terminals are immersed in rosin for 5 seconds and then immersed in solder bath of +270±5°C for 3±1 seconds.	90% min. lead terminals shall be wet with solder. (Except the edge of terminal)
2	Soldering Heat Resistance	Lead terminal are immersed up to 1.5mm from sounder's body in solder bath of +260±5°C for 3±1 seconds.	No interference in operation
3	Terminal Mechanical Strength	The force 10 seconds of 9.8N (1.0kg) is applied to each terminal in axial direction.	No damage and cutting off
4	Vibration	Buzzer shall be measured after being applied vibration of amplitude of 1.5mm with 10 to 55hz band of vibration frequency to each of 3 per-pendicular directions for 2 hours.	After the test the part shall meet specifications with-out any damage in appearance and the SPL should be in ±10dBA compared with initial one.
5	Drop test	The part only shall be dropped from a height of 75cm onto a 40mm thick wooden board 3 times in 3 axes (X.Y.Z). (a total of 9 times).	

Notes: 1. Not recommended for wave soldering

### ENVIRONMENT TEST

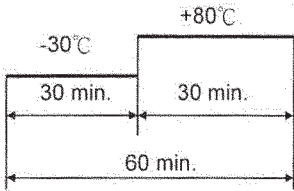
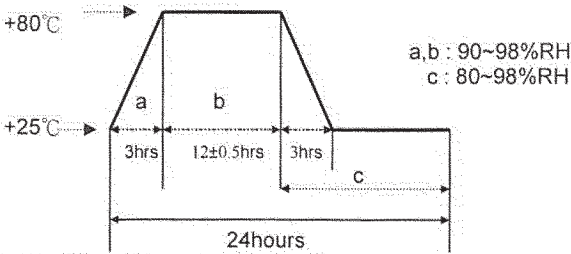
No.	Item	Test condition	Evaluation standard
1	High temp. test	After being placed in a chamber at +80°C for 96 hours.	After the test the part shall meet specifications with-out any degradation in appearance and performance except SPL. after 4 hours at +25°C. the SPL should be in ±10dBA compared with initial one.
2	Low temp. test	After being placed in a chamber at -30°C for 96 hours.	
3	Thermal Shock	The part shall be subjected to 10 cycles. One cycle shall consist of; 	
4	Temp./ Humidity Cycle	The part shall be subjected to 10 cycles. One cycle shall be 24 hours and consist of; 	

### RELIABILITY TEST

No.	Item	Test condition	Evaluation standard
1	Operating life test	1. Continuous life test The part shall be subjected to 72 hours at +55°C with 5V ,2730Hz applied.  2. Intermittent life test A duty cycle of 1 minute on, 1 minutes off, a minimum of 10000 times at room temp.( +25±10°C) with 5V ,2730Hz applied.	After the test the part shall meet specifications with-out any degradation in appearance and performance except SPL after 4 hours at +25°C. the SPL should be in ±10dBA compared with initial one.

#### TEST CONDITION.

Standard Test Condition : a) Temperature : +5 ~ +35°C b) Humidity : 45-85% c) Pressure : 860-1060mbar

Judgement Test Condition : a) Temperature : +25 ± 2°C b) Humidity : 60-70% c) Pressure : 860-1060mbar

### PACKING STANDARD

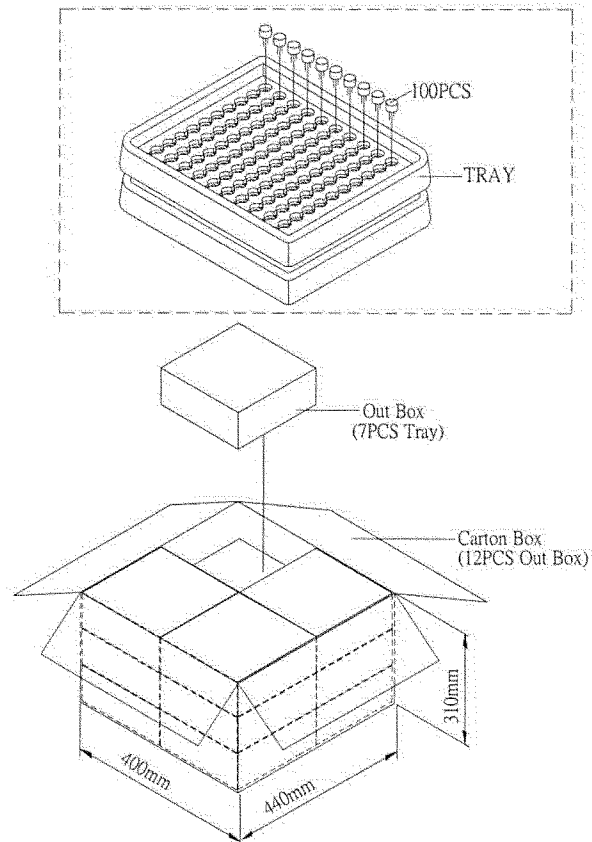

Tray	184mmx184mmx23mm	10x10PCS=100PCS
Out Box	200mmx190mmx100mm	7LAYERx100PCS=700PCS
Carton Box	440mmx400mmx310mm	700PCSx12=8400PCS